

Installation manual
(Translation of original language)

EN

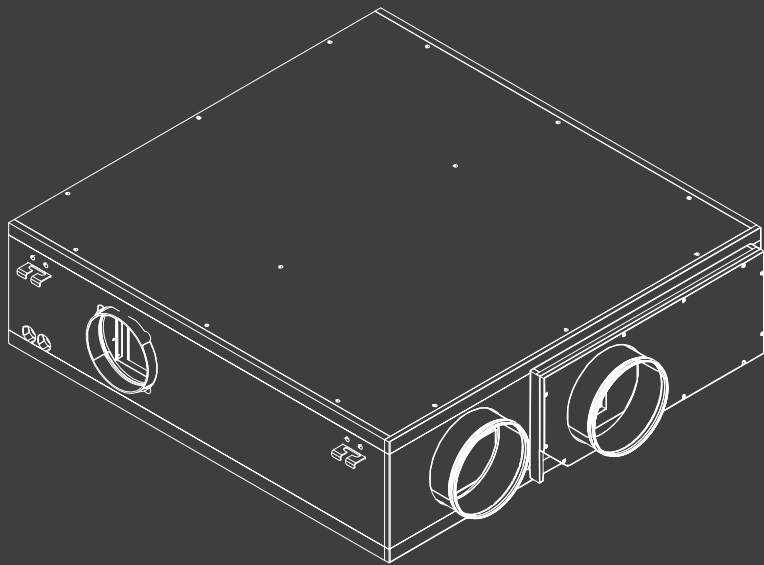

innova

N421223A Rev. 04 02/2026

HRA-i PLUS

**Air conditioning unit
standalone with heat recovery**

First of all, we would like to thank you for having chosen one of our units.

As you will realise, you have made a winning choice by purchasing a product that represents the state of the art in domestic air-conditioning technology.

Thanks to the product you have purchased and by following the suggestions in this manual, you will benefit from optimal environmental conditions with the lowest possible energy investment.

Compliance

This unit complies with European directives:

- Low Voltage Directive 2014/35/EU by transposition of the following technical standards: EN 60335-1:2012 + EN 60335-2-40:2003
- EMC Directive 2014/30/EU, by transposition of technical standards: EN 55014-1:2017 + EN 55014-2:2015 + EN 61000-3-2:2014 + EN 61000 3-3:2013
- RoHS Directive 2011/65/EU by transposition of the following technical standards: EN IEC 63000:2018
- RED Directive 2014/53/EU

Markings



CONTENTS

Compliance	2
Markings.	2

1. General information 4

1.1 About the manual	4
1.2 General warnings	5
1.3 Basic safety rules.	5
1.4 Disposal	6

2. Information on refrigerant R32. 7

2.1 Pictograms on the product.	7
2.2 General warnings	7
2.3 Safety rules	7
2.4 Electrical connections	7

3. Product introduction 9

3.1 Identification	9
3.2 Destination of use	9
3.3 Description of the appliance	9
3.4 List of external components	10
3.5 List of internal components	11
3.6 Compatible accessories	12

4. Installation 14

4.1 Preliminary warnings	14
4.2 Reception	14
4.3 Dimensions and weights with packaging	14
4.4 Handling with packaging	15
4.5 Storage.	15
4.6 Unpacking.	15
4.7 Handling without packaging.	16
4.8 Installation site.	16
4.9 Minimum installation distances.	18
4.10 Positioning	19
4.11 Condensate drain connection	20
4.12 Aeraulic connections.	21
4.13 Electrical connections	23

5. On-board display 29

5.1 Interface	29
5.2 Main functions	29
5.3 Warnings.	31

6. M7 series controls EEB733 MODBUS . . 33

6.1 Interface	33
6.2 Installation	34
6.3 Connection diagram	35
6.4 Connections.	37
6.5 Functions	38

7. M7 series controls EFB733 Wi-Fi 40

7.1 Interface	40
7.2 Installation	41
7.3 Connection diagram	42
7.4 Connections.	44
7.5 Functions	45

8. Start-up 47

8.1 First start-up	47
8.2 Plant delivery	48
8.3 Switching off for extended periods. . . .	48

9. Maintenance 49

9.1 Routine maintenance	49
-----------------------------------	----

10. Faults and remedies 53

10.1 Preliminary warnings	53
10.2 Troubleshooting table.	54

11. Technical information 55

11.1 Technical data.	55
11.2 Dimensions	58

1. GENERAL INFORMATION

1.1 About the manual

This manual was written to provide all the explanations for the correct management of the appliance.

- ⚠ This instruction manual is an integral part of the appliance and must therefore be kept in a safe place and must ALWAYS accompany the appliance even if it is passed on to another owner or user, or transferred to another plant. If it is damaged or lost, download a copy from the website.
- ⚠ Read this manual carefully before proceeding with any operation and follow the instructions in the individual chapters.
- ⚠ Specific warnings are given in each chapter of the document and should be read before starting operations.
- ⚠ The manufacturer accepts no liability for damage to persons or property resulting from failure to observe the regulations contained in this booklet.
- ⚠ This document is confidential under the terms of the law and may not be reproduced or passed on to third parties without the express authorisation of the Manufacturer.

Editorial pictograms

The pictograms in the following chapter provide quick and unambiguous information necessary for the correct and safe use of the machine.

Related to safety

⚠ High risk warning (bold text)

- The operation described above presents a risk of serious physical injury, fatality, major damage to the appliance and/or to the environment if not carried out in compliance with safety regulations.

⚠ Low risk warning (plain text)

- The operation described above presents a risk of minor physical injury or minor damage to the appliance and/or to the environment if not carried out in compliance with safety regulations.

🚫 Prohibition (normal text)

- Marks actions that are prohibited.

📌 Important information (bold text)

- This indicates important information that must be taken into account during the operations.

In the texts

Purpose of the actions

- ▶ Actions required

Expected responses following an action

- Lists

In the figures

- 1 The numbers indicate the individual components.

A Capital letters indicate a combination of components and dimensions.

- ① The white numbers in black marks indicate a series of actions to be carried out in sequence.
- Ⓐ The black letter in white identifies an image when there are several images in the same figure.

Pictograms on the product

Symbols are used in some parts of the appliance:

Related to safety



Read the instruction manual

Read the instructions carefully before performing any operation on the appliance.



Instruction manual

Read the information available in the technical documentation of the appliance.



Attention electrical hazard

- Warns relevant personnel of the presence of electricity and the risk of electric shock.

Recipients

User

Non-expert person capable of operating the product in safe conditions for people, for the product itself and the environment, interpreting an elementary diagnostic of faults and abnormal operating conditions, carrying out simple adjustment, checking and maintenance operations.

Installer

Expert person qualified to position and connect (hydraulically, electrically, etc.) the unit to the plant; this person is responsible for handling and correct installation according to the instructions provided in this manual and the national standards currently in force.

To perform work on the refrigeration circuit, the installer must comply with Regulation 2024/573/EU regarding the requirements for companies and personnel working with fixed refrigeration, air conditioning appliances, and heat pumps containing certain fluorinated greenhouse gases (F-gas license).

Service

Expert and qualified person authorised directly by the Manufacturer to carry out all routine and supplementary maintenance operations, as well as every adjustment, check, repair and replacement of parts necessary during the life of the unit.

Organisation of the manual

The manual is divided into sections each dedicated to one or more target groups.

General information

It addresses all recipients.

It contains general information and important warnings that should be known before installing and using the appliance.

Product introduction

Addressed to all recipients, contains general information on the product.

Installation

It is addressed exclusively to the installer.

It contains specific warnings and all the necessary information for the positioning, installation, and connection of the appliance.

Commissioning, maintenance and troubleshooting

They are addressed exclusively to the Authorised Service Centre.

It contains specific warnings and useful information for the most common commissioning and routine maintenance.

Technical information

It addresses all recipients.

It contains detailed technical information about the appliance.

1.2 General warnings

- ⚠ Specific warnings are given in each chapter of the document and should be read before starting operations.
- ⚠ All personnel involved must be aware of the operations and dangers that may arise when beginning all unit installation operations.
- ⚠ Installation performed outside the warnings provided in this manual and use of the appliance outside the prescribed temperature limits will invalidate the warranty.
- ⚠ The installation and maintenance of air conditioning equipment can be dangerous as they contain pressurised refrigerant gas and live electrical components. The installation, initial startup, and subsequent maintenance stages must be carried out exclusively by authorised and qualified personnel (see first startup request form attached to the equipment).
- ⚠ Any contractual or extra-contractual liability for damage caused to persons, animals or property, due to installation, adjustment and maintenance errors or improper use is excluded. All uses not expressly indicated in this manual are not permitted.
- ⚠ The installation of the appliances must be carried out by a qualified company which, on completion of the work, will issue a declaration of compliance to the person in charge of the plant in accordance with the regulations in force and the instructions provided in the instruction booklet accompanying the appliance.
- ⚠ First start-up and repair or maintenance operations must be carried out by the Authorised Service Centre or by qualified personnel following the provisions of this manual.
- ⚠ Do not modify or tamper with the appliance as this can lead to dangerous situations.
- ⚠ Use suitable personal protective clothing and equipment during installation and/or maintenance operations. The Manufacturer is not liable for the non-observance of the current safety and accident prevention regulations.
- ⚠ In case of liquid or oil leaks, isolate the main power supply of the system and close any water valves. Promptly contact the Authorised Service Centre or professionally qualified personnel, and refrain from personally intervening on the equipment.
- ⚠ When replacing components, use only original spare parts.
- ⚠ The Manufacturer reserves the right to make changes to its models at any time to improve its product, without prejudice to the essential characteristics described in this manual. The Manufacturer is not obliged to add such modifications to machines previously manufactured, already delivered, or under construction.
- ⚠ The appliance can be used by children aged 8 years and above and by persons with reduced physical, sensory, or mental capabilities, or those lacking experience or necessary knowledge, provided they are under supervision or have been given instructions concerning the safe use of the appliance and understand the hazards involved. Children should not play with the appliance. Cleaning and maintenance intended to be carried out by the user should not be done by children without supervision.

1.3 Basic safety rules

We would like to remind you that the use of products that use electricity and water involves observing certain basic safety precautions such as:

- ⊖ It is forbidden to touch the appliance with wet or damp body parts.
- ⊖ It is forbidden to carry out any operation before disconnecting the appliance from the power supply by setting the plant master switch to "OFF".
- ⊖ It is forbidden to modify the safety or adjustment devices without the authorisation and instructions of the appliance manufacturer.
- ⊖ It is forbidden to pull, unplug or twist the electrical cables coming out of the appliance, even if it is disconnected from the mains supply.
- ⊖ It is forbidden to introduce objects and substances through the openings provided for the intake and delivery of air.
- ⊖ It is forbidden to open the access doors to the internal parts of the appliance without first setting the plant master switch to "OFF".
- ⊖ It is forbidden to dispose of packaging material and leave it within reach of children as it can be a potential hazard.

1.4 Disposal



The symbol on the product or packaging indicates that the product should not be treated as normal household waste. Instead, it should be taken to an appropriate collection point for recycling of electrical, electronic, and battery equipment.

Proper disposal of this product avoids harm to humans and the environment and promotes the reuse of valuable raw materials.

For more detailed information about the recycling of this product, contact your local authority, your household waste disposal service, or the shop where you purchased the product.

Illegal disposal of the product by the user involves the application of the administrative sanctions provided for by the regulations in force.

This provision is only valid in the EU Member States.

- ⚠ Avoid disassembling the appliance yourself.
- ⚠ This unit contains fluorinated greenhouse gases covered by the Kyoto Protocol. Maintenance and disposal operations must be carried out by qualified personnel only.
- ⚠ **Contact an Authorised Service Centre to disassemble the appliance.**

2. INFORMATION ON REFRIGERANT R32

- ⚠ The appliance must be installed in well-ventilated environments that have a minimum floor area as indicated in the table "Minimum Floor Area" based on the total refrigerant charge of the circuit.
- ⚠ **The refrigerant charge refers to the total amount of refrigerant in the circuit, which includes the factory charge and any additional charge.**
- ⚠ Please refer to the technical rating plate on the associated outdoor unit for the quantity of refrigerant loaded into the unit.
- ⚠ If the appliance is placed in a poorly ventilated area, precautions must be taken to prevent the accumulation of leaked refrigerant, thus avoiding the risk of fire or explosion.
- ⚠ The appliance should be placed in a room where there are no continuously operating open flames (such as a gas appliance in operation) or ignition sources (such as an operating electric heater).
- ⚠ Any ventilation openings must be kept clear of obstacles.
- ⚠ Perform the following checks:
 - Perform safety checks to ensure that the risk of combustion is minimised
 - avoid working in confined spaces
 - delimit the area around the workspace
 - ensure safe working conditions around the area by checking for flammable materials

2.1 Pictograms on the product

Symbols are used in some parts of the appliance:



Warning flammable material

- The refrigerant gas R32 is mildly flammable and odourless. Avoid proximity to continuous ignition sources such as open flames, gas appliances, electric heaters, lit cigarettes, etc.



Instructions

- Read the instructions carefully before performing any operation on the appliance.



Instructions for Service

- The Authorised Service Centre must read the instructions before performing any operation on the appliance.



Instructions for the User

- Further information is available in the technical documentation of the appliance.

2.2 General warnings

The document only contains some of the safety rules regarding R32 refrigerant. For more comprehensive information, please read the safety data sheet available from the retailer.

- ⚠ In each chapter, specific warnings are included for the operations described within. These warnings should be read before starting any activities.
- ⚠ All precautions regarding the handling of refrigerant must be followed in accordance with current regulations.

- ⚠ The unit uses R32 refrigerant, with a Global Warming Potential (GWP) of 675. Do not release R32 gas into the atmosphere.
- ⚠ The R32 refrigerant gas is mildly flammable and odourless.
- ⚠ Do not place flammable objects (spray cans) within 1 meter of the air discharge.
- ⚠ Avoid proximity to continuously operating ignition sources (open flames, gas appliances, electric stoves, lit cigarettes, etc.).

2.3 Safety rules

The document only contains some of the safety rules regarding R32 refrigerant. For more comprehensive information, please read the safety data sheet available from the retailer.

- 🚫 Smoking is prohibited near the appliance.

- 🚫 The use of mobile phones is prohibited near the appliance.
- 🚫 The use of leak detectors with halogen lamps is prohibited.

2.4 Electrical connections

- ⚠ The R32 refrigerant gas is mildly flammable and odourless.

- ⚠ All precautions regarding the handling of refrigerant must be followed in accordance with current regulations.

- ⚠ Avoid proximity to continuously operating ignition sources (open flames, gas appliances, electric stoves, lit cigarettes, etc.).
- ⊖ Smoking is prohibited near the appliance.
- ⊖ The use of mobile phones is prohibited near the appliance.
- ⚠ Perform the following checks:
 - Perform safety checks to ensure that the risk of combustion is minimised
 - avoid working in confined spaces
 - delimit the area around the workspace
 - ensure safe working conditions around the area by checking for flammable materials

3. PRODUCT INTRODUCTION

3.1 Identification

The appliance can be identified by the rating plate:

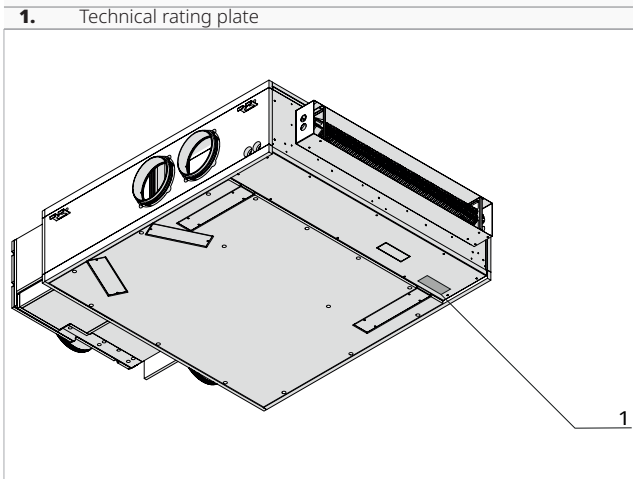

Technical rating plate

This shows the technical and performance specifications of the appliance.

- ⚠ According to EU Regulation No. 2024/573 on certain fluorinated greenhouse gases, it is mandatory to indicate the total amount of refrigerant present in the installed system. This information is available on the unit's nameplate.
- ⚠ Tampering with, removing or missing identification plates does not allow the product to be reliably identified by its serial number and therefore invalidates the warranty.

3.2 Destination of use

The unit is an active recovery system for heating, cooling, and air renewal in indoor environments.

The unit consists of a single block comprising all components for proper operation:

- fans
- refrigeration circuit with horizontal BLDC compressor

- air filtration sections ePM1 and Coarse ePM10
- high-efficiency heat recovery unit

The unit can operate as a passive recovery system and as an air conditioner.

It is particularly suitable for residential spaces, allowing for quick and simplified installation.

3.3 Description of the appliance

Structure: load-bearing in self-supporting sheet metal, insulated panels. Frame and internal closures in thick galvanized sheet metal.

Heat exchanger: Counterflow type, high-efficiency cross-flow polypropylene heat exchanger.

Brushless fans: electronically regulated AC fans with internal circuit allowing for high levels of comfort and energy efficiency.

Filters: EPM1 filter on supply air and on exhaust air in heat recovery, and Coarse ePM10 in air recirculation with low pressure drop. Easily removable for routine maintenance.

Refrigeration circuit: made of brazed copper with high-efficiency dual rotary BLDC inverter compressor, dehydrator filter, finned coils, electronic expansion valve, and reversing valve for season change.

3.4 List of external components

Unit with post heating

- | | |
|-----------------------------|---|
| 1. Extract air | 4. Outdoor air exhaust (PDC) and stale air exhaust (VMC) |
| 2. Air recirculation | 5. Outdoor air intake (PDC) and Fresh air inlet (VMC) |
| 3. Supply air | |

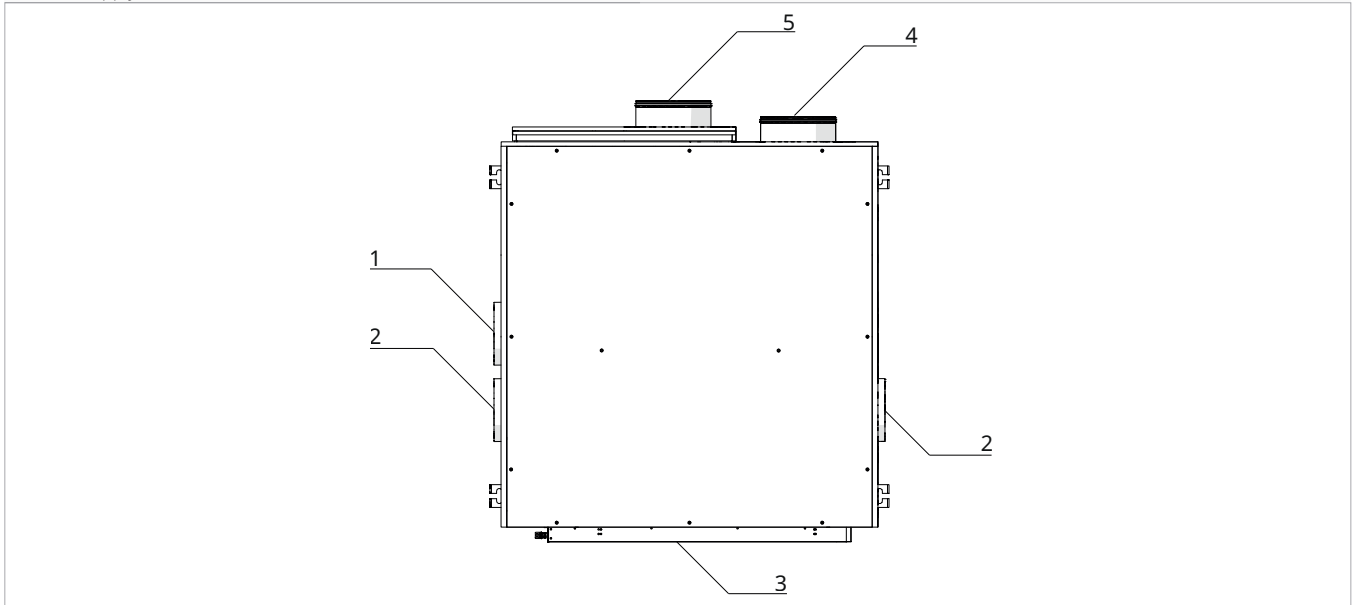

- | | |
|---|----------------------------|
| 1. Electrical connection passage | 3. Condensate drain |
| 2. Installation bracket | |

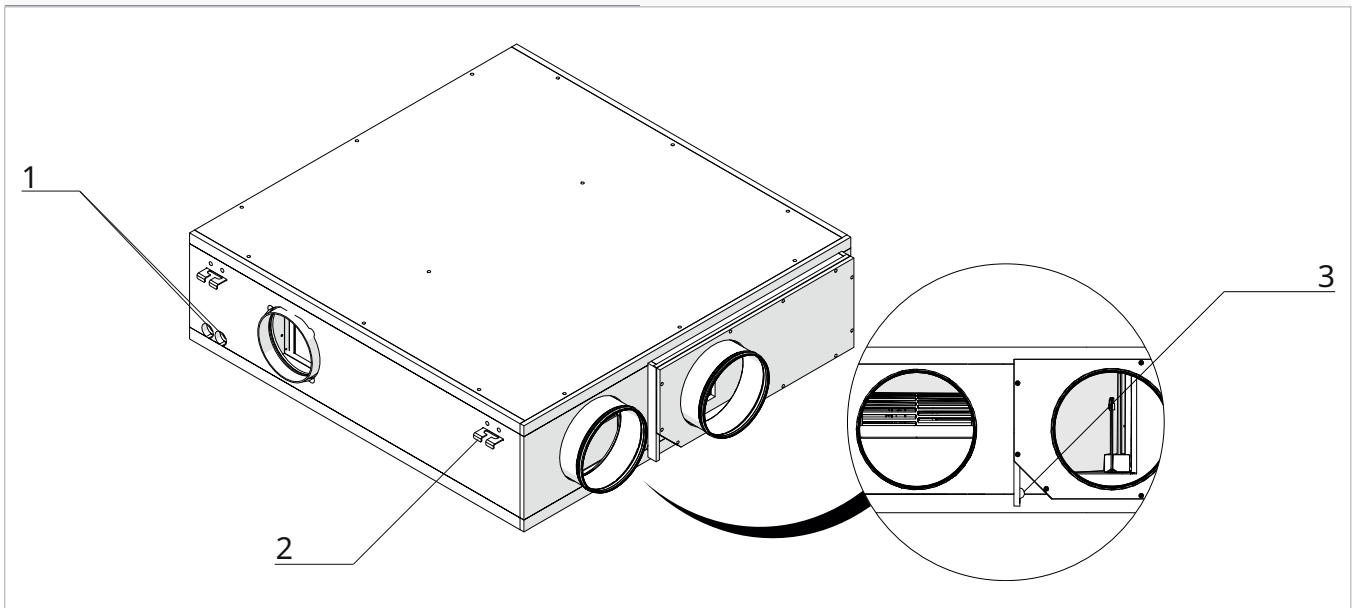

3.5 List of internal components

Unit with post heating

1.	Exhaust fan on external side	8.	Heat exchanger
2.	Outdoor side coil	9.	VMC Extract air filter
3.	Prefilter	10.	Air recirculation filter
4.	VMC Stale air exhaust fan	11.	Electrical panel
5.	VMC Fresh air inlet fan	12.	Supply fan
6.	Pre heater electrical panel	13.	Indoor side coil
7.	VMC Fresh air inlet filter	14.	Compressor

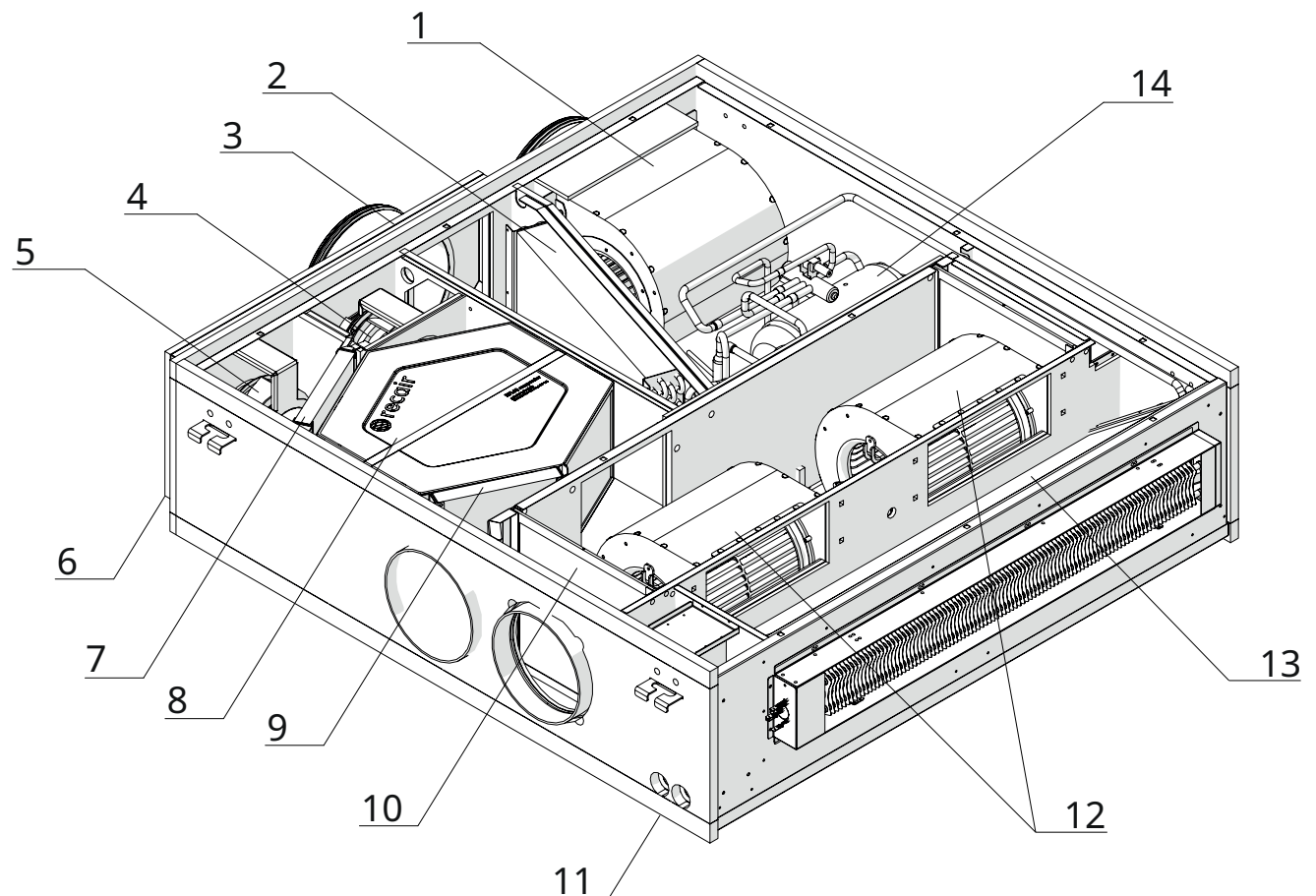

3.6 Compatible accessories

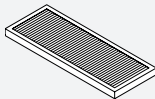
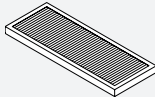
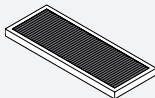
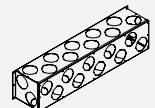
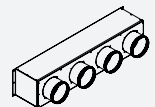
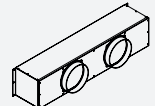
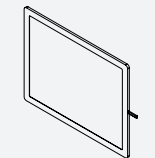
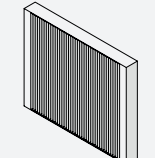
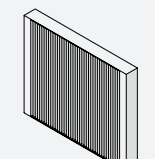
Description		Code
Commands		
	Electronic LED control panel with touch interface, wall-mounted installation complete with thermostat and temperature and relative humidity sensor in the environment. Wired connection. White color	EEB733II
	LED electronic control panel with touch interface, wall installation complete with thermostat and ambient temperature and relative humidity sensor, with integrated Wi-Fi module. Wired connection. White color.	EFB733II
Wall recessed boxes		
	Wall recessed box for masonry Wall recessed box for plasterboard	N000557AII N000558AII
Spare filters		
	FDR - Kit 2 replacement G2 filters for side recirculation	AHRA0687II
	FDR - Replacement kit with 2 ePM1 filters	AHRA0685II
Activated carbon replacement filters		
	FCA - Activated carbon filter	AHRA0686II
Distribution manifolds		
	Insulated plenum with unit connection flange and pre-cut openings for DN 75 / DN 90 corrugated conduits 2+10+2 (810x175x175 mm)	AHRA0712II
	Insulated plenum with unit connection flange and four DN 125 mm circular duct connections (810x175x175 mm)	AHRA0713II
	Insulated plenum with unit connection flange and two DN 160 mm circular duct connections (810x175x175 mm)	AHRA0706II
Filters for bottom flange		
	Kit 2 Coarse ePM10 filters - MERV 3	AHRA2015II
	Kit with 2 filters ePM2.5 - MERV 8	AHRA2016II
	Kit 2 ePM1 - MERV 13 filters	AHRA2017II
Electric pre-heating finned coil for external air		

Description		Code
	Heating coil with fixed-point thermostat / DN 200. 1 kW	AHRP0281II
Insulated air supply/return plenum		
	Insulated plenum for air supply/return with 2 DN 160 inlets, 1 DN 160 cap and grille connection. Dimensions: 420x200x200 mm. Male connections	AHRA0708II
Distribution accessories		
	Aluminium air supply grille with double row of adjustable blades. White colour. Size 450x225 mm	AHRA0709II
	Intake grille with removable aluminium filter. White colour. Size 450x225 mm	AHRA0710II
Activated carbon filters		
	FCA - Activated carbon filter	AHRA0686II
Standard replacement filters		
	FDR - Replacement kit with 2 recirculation filters	AHRA0687II
	FDR - Replacement kit with 2 ePM1 filters	AHRA0685II
	FDR - Kit with 2 replacement recirculation filters + 2 replacement PM1 filter kits	AHRA0688II

4. INSTALLATION

4.1 Preliminary warnings

- ⚠ **For safety warnings, requirements, checks and procedures related to the refrigerant, refer to the section "Information related to the refrigerant".**
- ⚠ The installation must be carried out by the installer. There is a risk of water leakage, electric shock or fire if the installation is not performed correctly.
- ⚠ During installation, it is necessary to observe the precautions mentioned in this manual, and on the labels affixed to the inside of the appliances, as well as to take

every precaution suggested by common sense and the safety regulations in force at the place of installation.

- ⚠ Using only the supplied installation-specific components is recommended. Use of alternative components could lead to water leakage, electric shock or fire.
- ⚠ Failure to apply the indicated rules may cause malfunctions of the appliance and relieves the Manufacturer from any warranty and from any damage caused to persons, animals or property.

4.2 Reception

Preliminary warnings

- ⚠ **For safety warnings, requirements, checks and procedures related to the refrigerant, refer to the section "Information related to the refrigerant".**
- ⚠ Upon receipt of the package check that it is not damaged, otherwise accept the goods with reservation, producing photographic evidence of any damage.
- ⚠ In the event of damage, notify the shipper by registered mail with return receipt within 3 days of receipt. Presenting photographic documentation, similar information should also be sent by email to the Manufacturer.
- ⚠ No reports of damage will be taken into account later than 3 days after delivery.

- ⚠ The packaging should be transported in a horizontal position without tilting. If it is tilted, please notify the carrier immediately.

Package description

The packaging is made of suitable material and carried out by experienced personnel. The units are all checked and tested and are delivered complete and in perfect condition. The appliance is shipped in standard packaging consisting of a cardboard box and a set of polystyrene foam protectors, placed on a wooden pallet and secured with straps.

4.3 Dimensions and weights with packaging

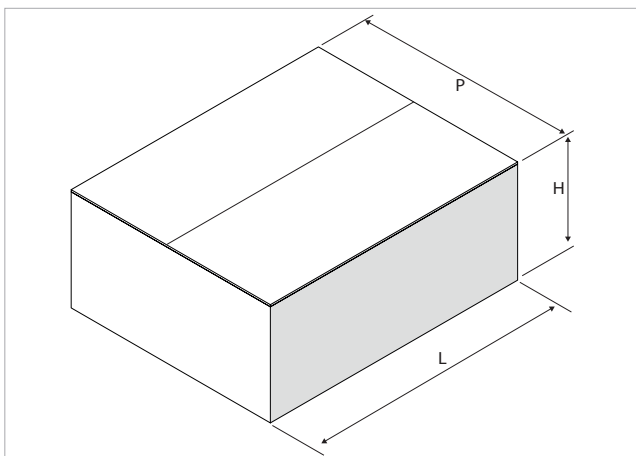

Models	u.m.	50/15-Post heating-0
Packaging dimensions		
Width	mm	1.120
Length	mm	1.245
Height	mm	375
Weight	kg	86,0

4.4 Handling with packaging

Preliminary warnings

- ⚠ **For safety warnings, requirements, checks and procedures related to the refrigerant, refer to the section "Information related to the refrigerant".**
- ⚠ The product should only be handled by qualified personnel, adequately equipped, and using tools suitable for the weight and dimensions of the product.
- ⚠ Before each handling operation, check the lifting capacity of the machinery used in accordance with the indications on the packaging.

Handling

With pallet:

- ▶ use a forklift

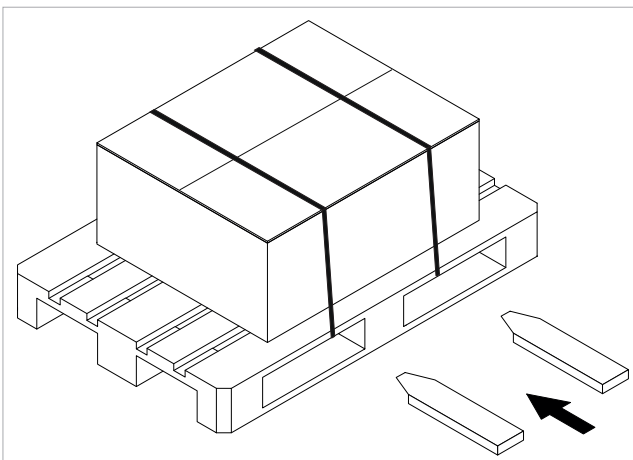

- ⚠ The packaging must be transported in a horizontal position without being tilted.
- ⚠ When the load is lifted from the ground, stay clear of the immediate and surrounding area.
- ⚠ Check the information on the packaging for the amount of stackable packages.
- ⚠ In manual operations, the maximum weight per person required by current legislation must always be observed.

Without pallet:

- ▶ use a forklift
- ⚠ The unit can only be moved manually for short trips in exceptional cases. In this case it is necessary to carefully check that the weight of the unit does not exceed what is stipulated by the regulations with respect to the number of persons employed.

4.5 Storage

Preliminary warnings

- ⚠ **For safety warnings, requirements, checks and procedures related to the refrigerant, refer to the section "Information related to the refrigerant".**
- ⚠ Stored in accordance with the applicable national regulations.

- ⚠ Store in a closed environment protected from the weather, off the ground by means of sleepers or pallets with temperatures not below 0 °C, up to a maximum of 40 °C.
- ⚠ Do not overturn the packaging.
- ⚠ Place the device only in a horizontal position.

4.6 Unpacking

Preliminary warnings

- ⚠ **For safety warnings, requirements, checks and procedures related to the refrigerant, refer to the section "Information related to the refrigerant".**
- ⚠ Check that the individual components are present.
- ⚠ Check that no components were damaged during transport.
- ⚠ Dispose of the packaging components following the applicable waste disposal regulations. Check for disposal arrangements with your local authority.
- ⚠ Handle with care.

- ⚠ The device must always be moved in a horizontal position.
- ⊖ The packing material (cardboard, staples, plastic bags, etc.) must not be dispersed or abandoned in the surrounding environment and must be kept out of reach of children due to risk of hazard.

Removing the packaging

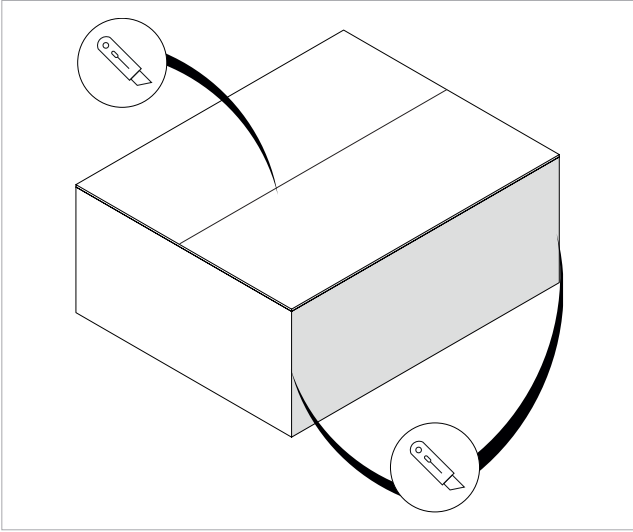

To remove the packaging:

- ▶ use a cutter
- ▶ open the cardboard packaging
- ⓘ To aid removal of the product, also cut the vertical edges.
- ▶ remove the accompanying components
- ▶ remove the polystyrene elements
- ▶ remove the appliance from the box

Accompanying material

They are included with the appliance, inside the packaging:

- Installer manual
- ⚠ Check the presence of the individual components.

4.7 Handling without packaging

Preliminary warnings

- ⚠ For safety warnings, requirements, checks and procedures related to the refrigerant, refer to the section "Information related to the refrigerant".
- ⚠ The unit must be handled using non-slip gloves.
- ⚠ The product should only be handled by qualified personnel, adequately equipped, and using tools suitable for the weight and dimensions of the product.
- ⚠ Before each handling operation, check the lifting capacity of the machinery used in accordance with the indications on the packaging.
- ⚠ When the load is lifted from the ground, stay clear of the immediate and surrounding area.

- ⚠ Check the information on the packaging for the amount of stackable packages.
- ⚠ In manual operations, the maximum weight per person required by current legislation must always be observed.

Movement methods

- ▶ use a fork lift, scaffolding or other suitable lifting system
- ⚠ The unit can only be moved manually for short trips in exceptional cases. In this case it is necessary to carefully check that the weight of the unit does not exceed what is stipulated by the regulations with respect to the number of persons employed.

4.8 Installation site

The location of the appliance must be determined by the plant engineer or a competent person and must take into account both purely technical requirements and any national/local legislation in force.

The appliance is intended to be installed indoors in a horizontal position fixed to the ceiling.

- ⚠ The installation position must be chosen close to a wall connected to the outside.
- ⚠ The appliance is declared IPX0 protected, therefore not suitable for installation outdoors or in rooms with the presence of water (swimming pool, etc.).

Preliminary warnings

- ⚠ For safety warnings, requirements, checks and procedures related to the refrigerant, refer to the section "Information related to the refrigerant".
- ⚠ Avoid installing the unit in the vicinity of:
 - obstacles or barriers that cause recirculation of the exhaust air

- narrow places where the sound level of the appliance can be enhanced by reverberations or resonances
- environments with the presence of flammable or explosive gases
- very damp environments (laundries, greenhouses, bathrooms with high humidity, etc.) to prevent the formation of condensation on the external panels of the unit
- environments with the presence of flammable or explosive gases or flammable fluids
- solar radiation and proximity to heat sources
- ⚠ **Pay particular attention when installing near the sea. Salt-laden atmospheres can cause corrosion and oxidation of internal components, compromising the unit's operation.**
- ⚠ Avoid placing the unit within 1 metre of radio and video equipment.
- ⚠ Do not install above heat sources.
- ⚠ Ensure that:

- the installation site of the unit must be chosen with the utmost care to guarantee adequate protection from shocks and consequent damage
- the supporting surface is capable of supporting the weight of the appliance
- the supporting surface does not affect load-bearing building elements, piping, or power lines
- the functionality of load-bearing elements is not compromised
- there are no obstacles to the free circulation of air through the holes (plants, leaves...)
- the appliance must be installed in a position where it can be easily serviced
- the safety distances between the units and other appliances or structures are scrupulously respected so that the air entering and leaving the fans is free to circulate
- ⚠ If the unit is installed incompletely or on an unsuitable surface, it could cause damage to persons or property if it becomes detached.
- ⚠ The appliance must not be in a position where the air flow is aimed directly at a person.
- ⚠ Provide the following:
 - a drain nearby for the outflow of condensation
 - a compliant power supply nearby

4.9 Minimum installation distances

The clearance zones for the installation and maintenance of the appliance are shown in the figure below. Established spaces are necessary to avoid barriers to airflow and allow for normal cleaning and maintenance.

⚠ Make sure that there is sufficient space to allow the panels to be removed for routine and supplementary maintenance operations.

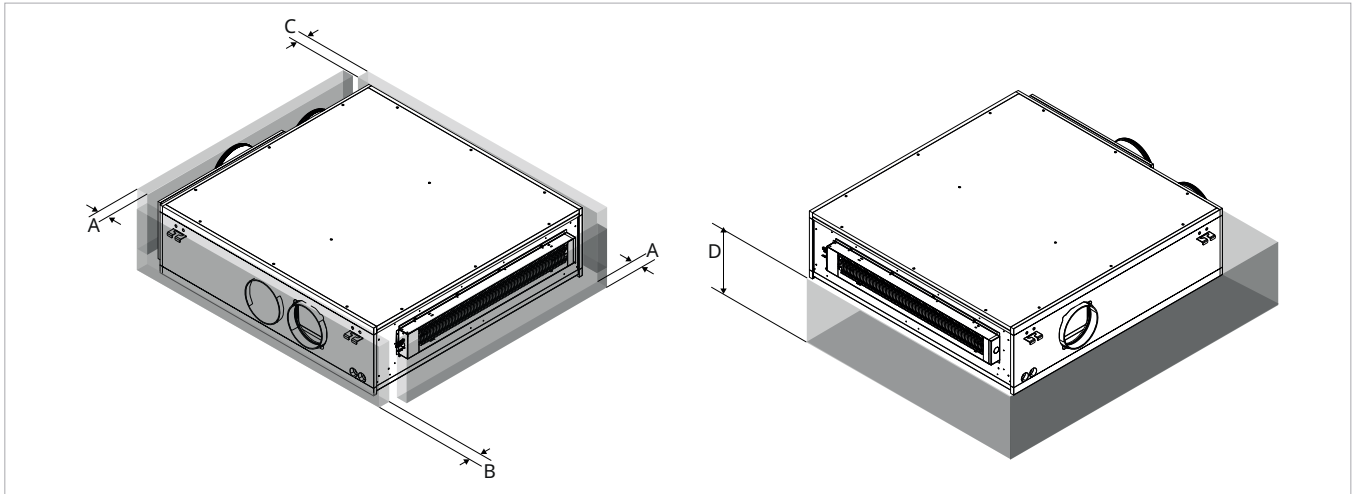

Models	u.m.	50/15
Minimum distances		
A	mm	50
B	mm	50
C	mm	50
D	mm	300

Hatch dimensions

⚠ For installation in a ceiling, it is mandatory to create an access hatch for the inspection and maintenance of the device.

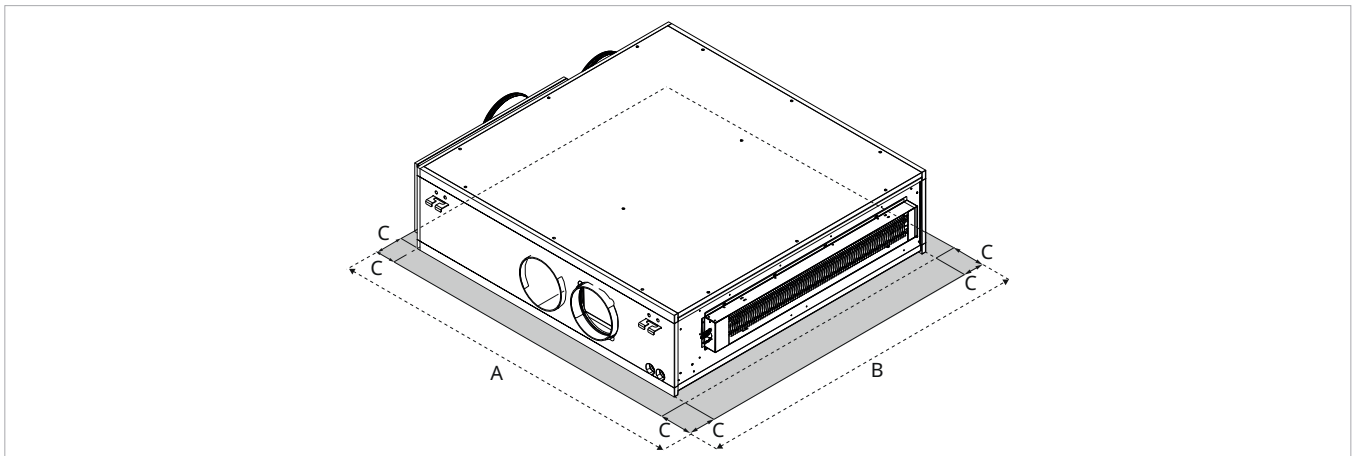

Models	u.m.	50/15
Hatch dimensions		
A	mm	1.427
B	mm	1.152
C	mm	50

4.10 Positioning

Preliminary warnings

- ⚠ **For safety warnings, requirements, checks and procedures related to the refrigerant, refer to the section "Information related to the refrigerant".**

The unit must be installed to a secure structure above the unit.

- ⚠ Check that:

- the surface supports the weight of the appliance
- the surface does not affect piping or power lines
- the functionality of load-bearing elements is not compromised

Drilling the outside wall

The external wall must be prepared with holes for air ducting.

To drill the holes:

- ▶ mark the position of the hole
- ▶ use a drill
- ▶ drill a guide hole
- ▶ use a core drill
- ▶ make a hole through the wall
- ▶ maintain a downward slope towards the outside
- ⚠ To avoid the release of large amounts of dust and debris into the room, you are advised to couple the core drill with a vacuum system.
- ⚠ Proceed with caution near the outside wall to avoid breaking the plaster around the hole.
- ⚠ Take precautions so that the removed material does not hit people and objects below.

Positioning the unit

- | | |
|----|----------------------|
| 1. | Installation bracket |
| 2. | Front side of unit |
| 3. | Rear side of unit |
| 4. | Electrical panel |

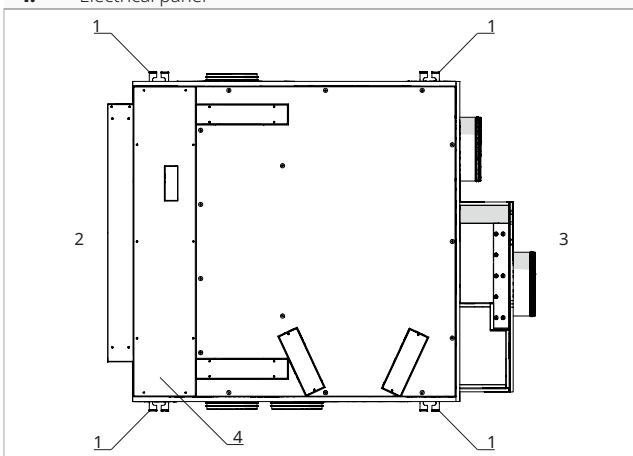

- ⚠ Check the correct orientation of the unit.
- ▶ mark the position of the fixing holes

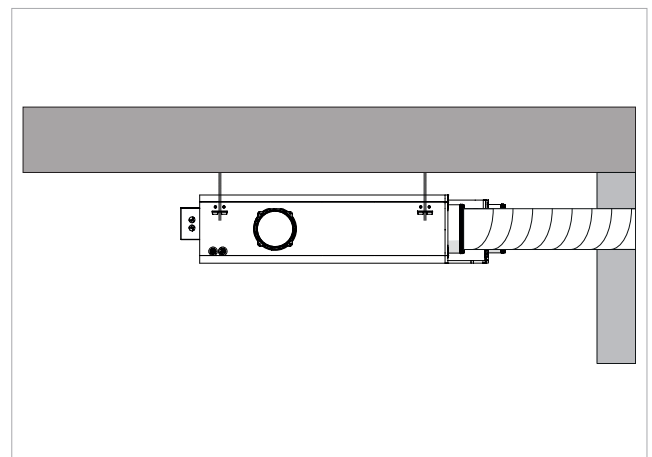
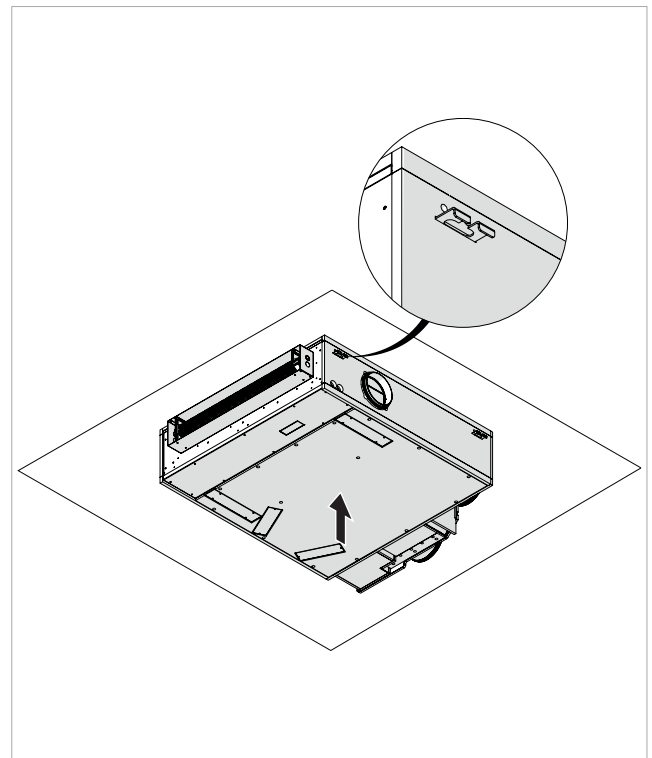

- ▶ use fixing systems appropriate for the type of supporting surface and the weight of the unit
- ▶ secure the unit to the fixing system
- ⚠ Check the horizontal alignment of the installation using a bubble level.

4.11 Condensate drain connection

Preliminary warnings

- ⚠ **For safety warnings, requirements, checks and procedures related to the refrigerant, refer to the section "Information related to the refrigerant".**
- ⚠ This appliance is equipped with trays for collecting the condensate that is produced during operation. Condensate must be routed to a suitable place for drainage.
- ⚠ The appliance is equipped with two condensate drainage connections. One of the two must be used depending on the chosen configuration.
- ⚠ If the drainage line runs into a container (tank or other) it must be ensured that the container itself is hermetically sealed and most importantly it must be ensured that the drainage pipe is not immersed in water.
- ⚠ The hole for the condensate pipe must always have an downwards slope.
- ⚠ When connecting the condensate drain, take care not to crush the rubber pipe.

Attachment position

The size and position of the condensate drain attachments are shown below.

1. Condensate drain Ø 18

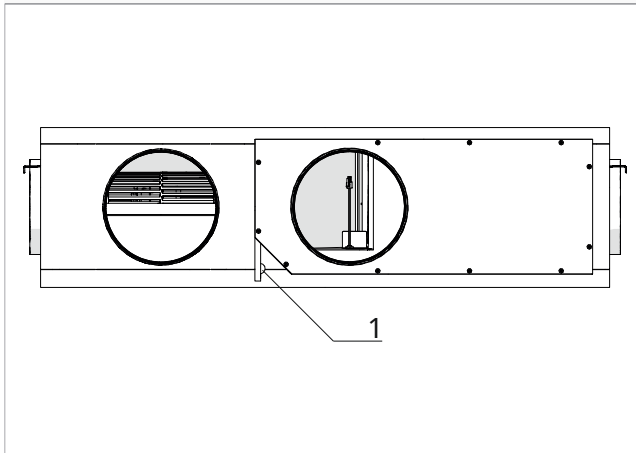

Connections

- 1. Condensate drain connection
- 2. Condensate drain pipe
- 3. Hose clamp

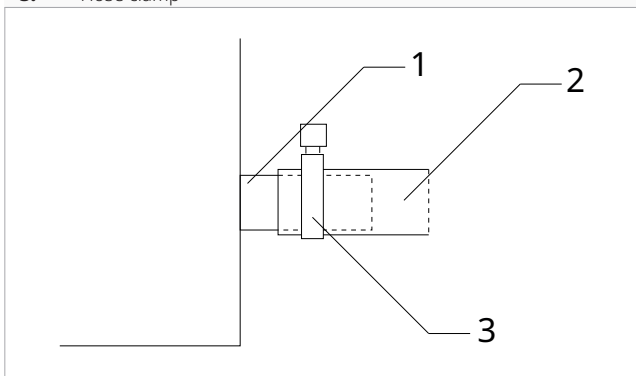

1. Unit

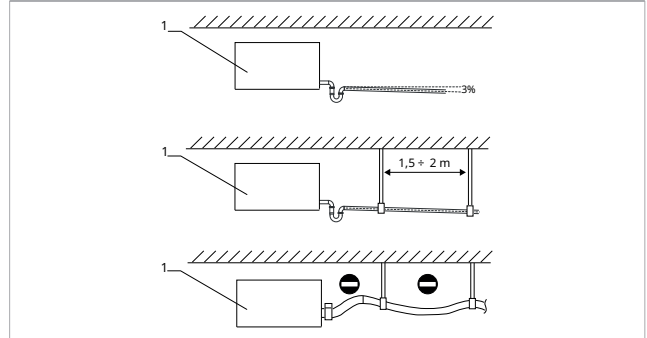

HT	100 mm
H1	50 mm
H2	50 mm

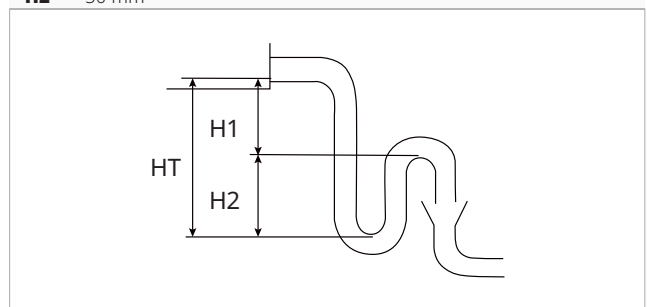

To connect the drain:

- ▶ connect the drainage pipe to the connection provided on the unit
- ▶ install a siphon on the condensate drainage pipe near the unit
- ▶ direct the condensate drain pipe to a suitable place for draining
- ▶ maintain a minimum slope of 3% towards the drain location
- ▶ insulate junction points
- ⚠ **It is mandatory to install an adequate siphon on the condensate drainage pipe to prevent the negative pressure generated by the fans from obstructing the proper flow of condensate, which could lead to spillage inside the premises.**
- ⚠ The drainage system must include a suitable siphon to prevent unwanted air from entering the vacuum system. The siphon also prevents the entry of odours or insects.
- ⚠ The siphon must be fitted with a plug at the bottom or must in any case permit quick dismantling for cleaning.
- ⚠ Use plastic drainage pipes.
- ⚠ Avoid metal pipes.
- ⚠ Make sure all joints are sealed to prevent leakage of water.
- ⚠ Condensate drain pipes must be insulated for both indoor and outdoor sections to avoid condensation on the surface and/or frosting problems. The insulation must be inserted all the way to the condensate drain pipe connection on the unit.

4.12 Aeraulic connections

Preliminary warnings

- ⚠ For safety warnings, requirements, checks and procedures related to the refrigerant, refer to the section "Information related to the refrigerant".
- ⚠ The sizing of ducting and supply and extract grilles must be carried out by a professionally qualified person.

- ⚠ To prevent the transmission of any vibrations of the machine into the room, an anti-vibration joint should be placed between the fan outlets and the ducts.
- ⚠ The connecting pipes must be of a suitable diameter and supported so that their weight does not put strain on the appliance.

Connections

- A** Air recirculation
- B** Extract air
- C** Outdoor air exhaust (PDC) and stale air exhaust (VMC)
- D** Outdoor air intake (PDC) and Fresh air inlet (VMC)

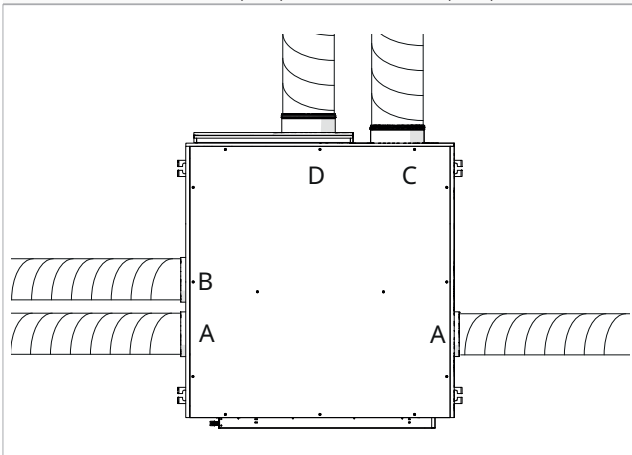

- 1. Extract air
- 2. Air recirculation

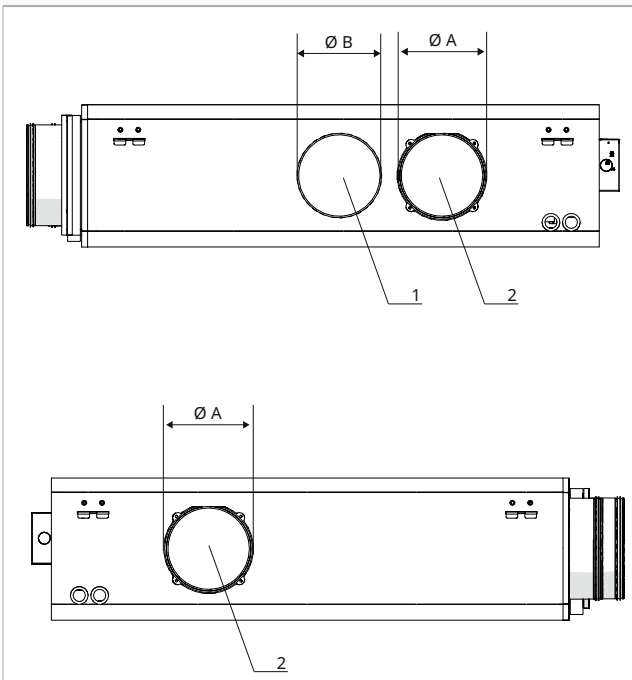

Models	u.m.	50/15
Product dimensions		
Air connection A	mm	160
Air connection B	mm	160

- 1. Outdoor air exhaust (PDC) and stale air exhaust (VMC)
- 2. Outdoor air intake (PDC) and Fresh air inlet (VMC)

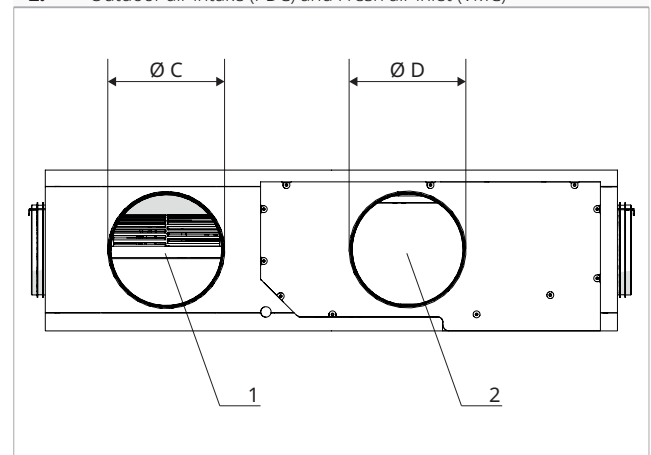

Models	u.m.	50/15
Product dimensions		
Air connection C	mm	200
Air connection D	mm	200

Circular connections

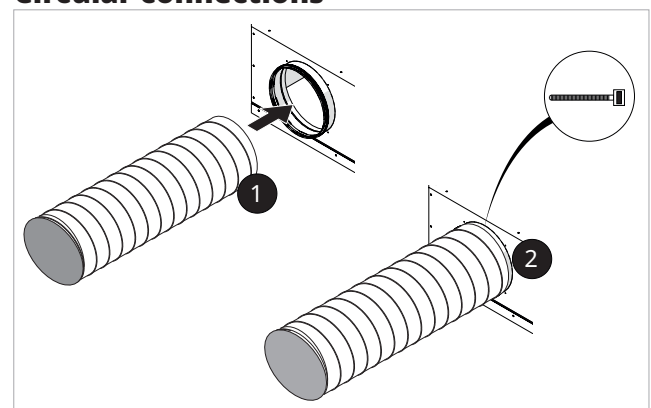

- ▶ position the ducts on the connections provided on the appliance
- ▶ use a metal clamp or duct fixing collar

- ▶ fix the ducts on the attachments
- ⚠ Use ducts lined with anti-condensation material of a suitable thickness.

Supply air

1. Fixing holes position

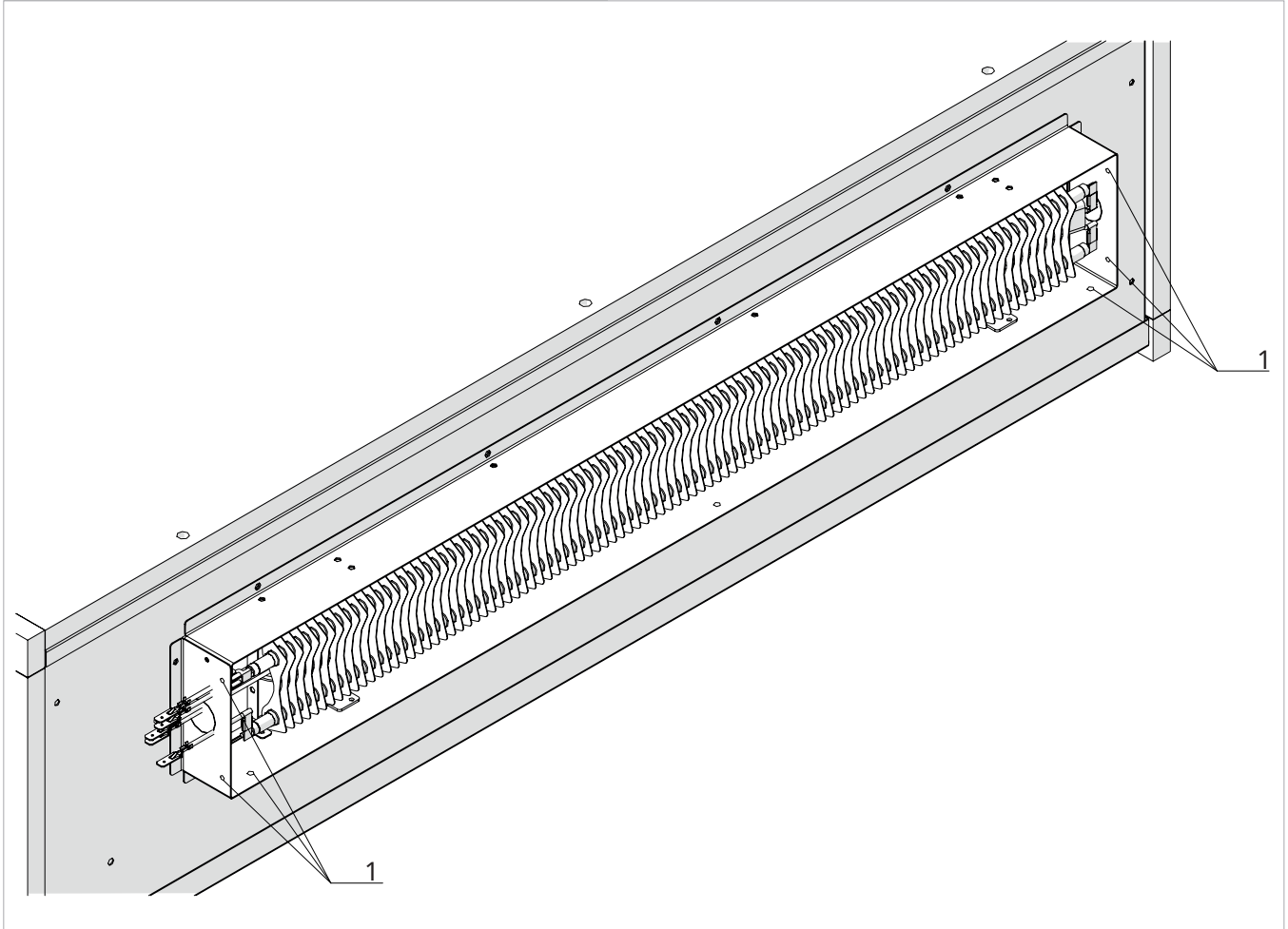

A 10 mm

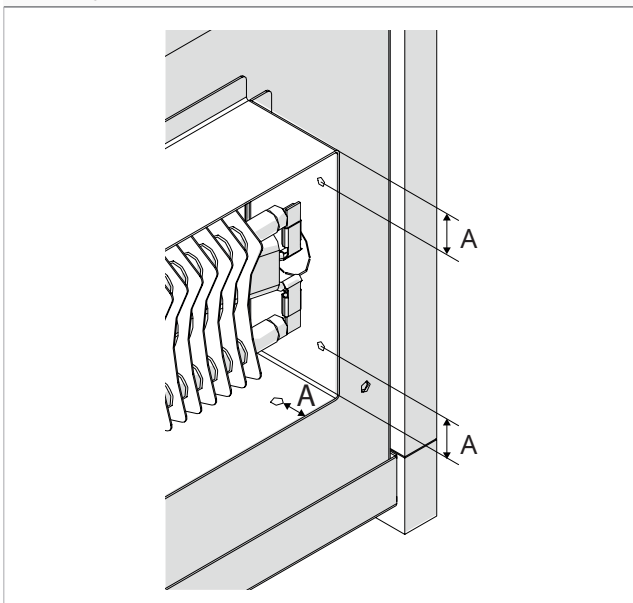

- ▶ fix the duct to the intake flange
- ▶ use self-drilling screws
- ⚠ **Use only screws with a maximum length of 10 mm; using longer screws may damage the device or impair its performance.**

4.13 Electrical connections

The appliance leaves the factory fully wired and only requires connection to the power supply, control and any accessories.

Preliminary warnings

⚠ For safety warnings, requirements, checks and procedures related to the refrigerant, refer to the section "Information related to the refrigerant".

⚠ All operations of an electrical nature must be carried out by suitably qualified personnel having the necessary legal knowledge and informed about the risks related to such operations.

⚠ All connections must be made in accordance with the relevant regulations in force in the country of installation.

⚠ Before carrying out any work, make sure that the power supply is switched off.

⚠ The unit should only be powered after the plumbing and electrical work has been completed.

⚠ References:

- for electrical connections please refer to the wiring diagrams in this manual, especially for the part concerning the power terminal board

⚠ Check that:

- the main supply characteristics are adequate for the power consumption of the appliance, also taking into account any other machinery in parallel operation
- the power supply voltage and frequency correspond to those specified on the nameplate of the appliance
- the cables are suitable for installation in accordance with the IEC standards in force
- the power supply is adequately protected against overloads and/or short circuits
- the disconnection device is positioned in an easily accessible place to enable intervention in the event of an emergency

⚠ It is mandatory:

- to connect the appliance to an effective grounding system
- for units with three-phase power supply, check the correct phase connection
- provide an all-pole switch with a contact opening distance of at least 3 mm that allows complete disconnection under overvoltage category III conditions
- Install a ground fault circuit interrupter (GFCI). Failure to install this device could result in electric shock
- provide a device for disconnecting all terminals during the installation of units in the field

⚠ Ensure that a connection to earth is made. Do not ground the appliance to distribution pipes, surge arresters or the ground of telephony systems. If not performed correctly, grounding can cause an electric shock. Momentary high voltage surges caused by lightning or other causes could damage the heat pump.

⚠ Use a dedicated power supply circuit. Never use a power supply to which another appliance is also connected due to risk of overheating, electric shock or fire.

⚠ For the electrical connection, use a cable of sufficient length to cover the entire distance without any connection. Do not use extension cables. Do not apply other loads on the power supply.

⚠ After connecting the interconnection and power supply cables, ensure that the cables are arranged so that they do not exert excessive forces on the covers or electrical panels. Install the covers on the cables. Incomplete connections of the covers can lead to overheating of the terminals, electric shock or fire.

⚠ Any replacement of the power cable must only be carried out by qualified personnel and in accordance with current national regulations.

⚠ The manufacturer is not liable for any damage caused by the lack of earthing or failure to comply with the specifications in the respective diagrams.

⚠ The appliance is equipped with a noise filter as required by current regulations. Use selective residual current circuit breakers to compensate for the micro leakage to earth of this device.

⚠ Use an appropriate section

⊖ Using gas and water pipes to ground the appliance is prohibited.

Power line dimensioning

Use the tables below for the sizing of the power supply line and its protection device.

These are not average draw or transient peaks, but values to be considered for the correct sizing of the plant and the request of the contractual power (excluding loads due to the normal operation of the building).

- ⚠ Maximum power is reached only in exceptional cases. Therefore, the indicated trip current is suggested to guarantee a balance between machine absorption and incidence in the general system.
- ⚠ The indicated minimum cable cross-section area must be verified according to the actual conditions of the installation: length of the cable, characteristics of the electrical supply, etc.
- ⚠ Cable section 2.5 mm²

Models	u.m.	50/15
Electrical characteristics		
Power supply	V / ph / Hz	230 / 1 / 50
Maximum total absorbed power	W	3.703
Maximum total absorbed current	A	16,10
Protection rating	IP	20

Access to the electrical panel

- ⚠ Access to the electrical panel is only permitted to qualified personnel.
- ⚠ Before carrying out any work, ensure that the power supply is switched off.

Connections

Before connecting the unit to the mains power supply, make sure that the isolator is open. The power supply of the single-phase unit must be connected to the appropriate terminals, subjected to the action of the isolating switch.

- ⚠ Use properly sized cables to avoid voltage drops or overheating.

1. Electrical connections passthrough

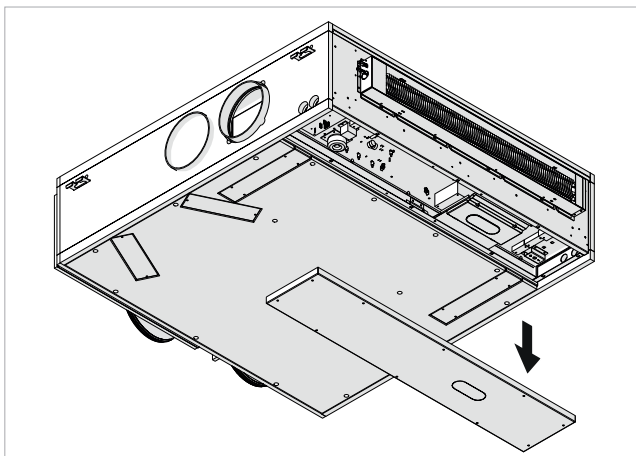
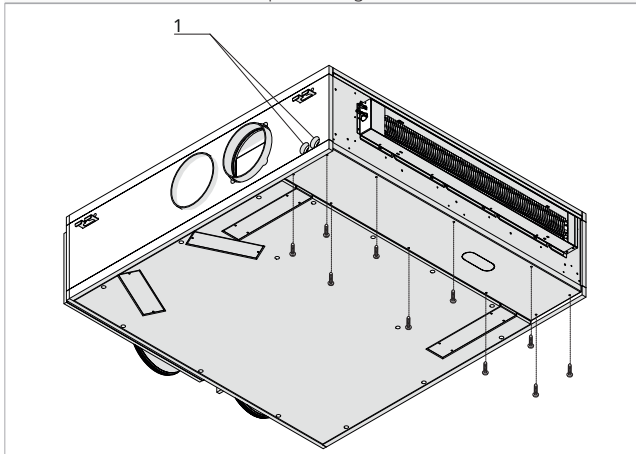

To access the connections:

- ▶ undo the fixing screws
- ▶ remove the electrical panel closing panel

Connection diagram

1. Power supply 230/1/50 (min 208 - max 240)
2. Isolator
3. Power cable

4. Remote control
5. Wired controller communication cable
6. Unit

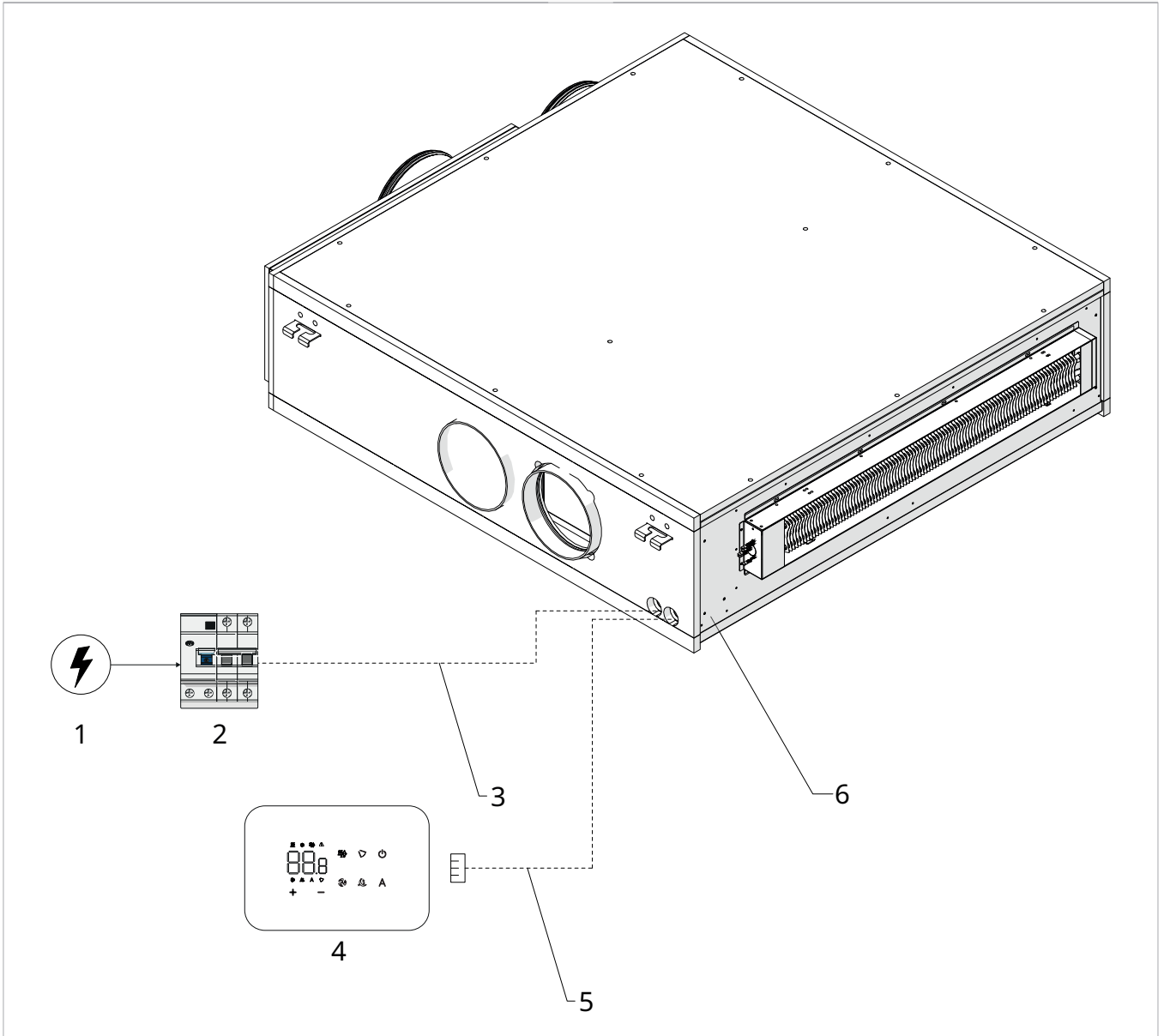

On-board electrical panel

Wiring diagram

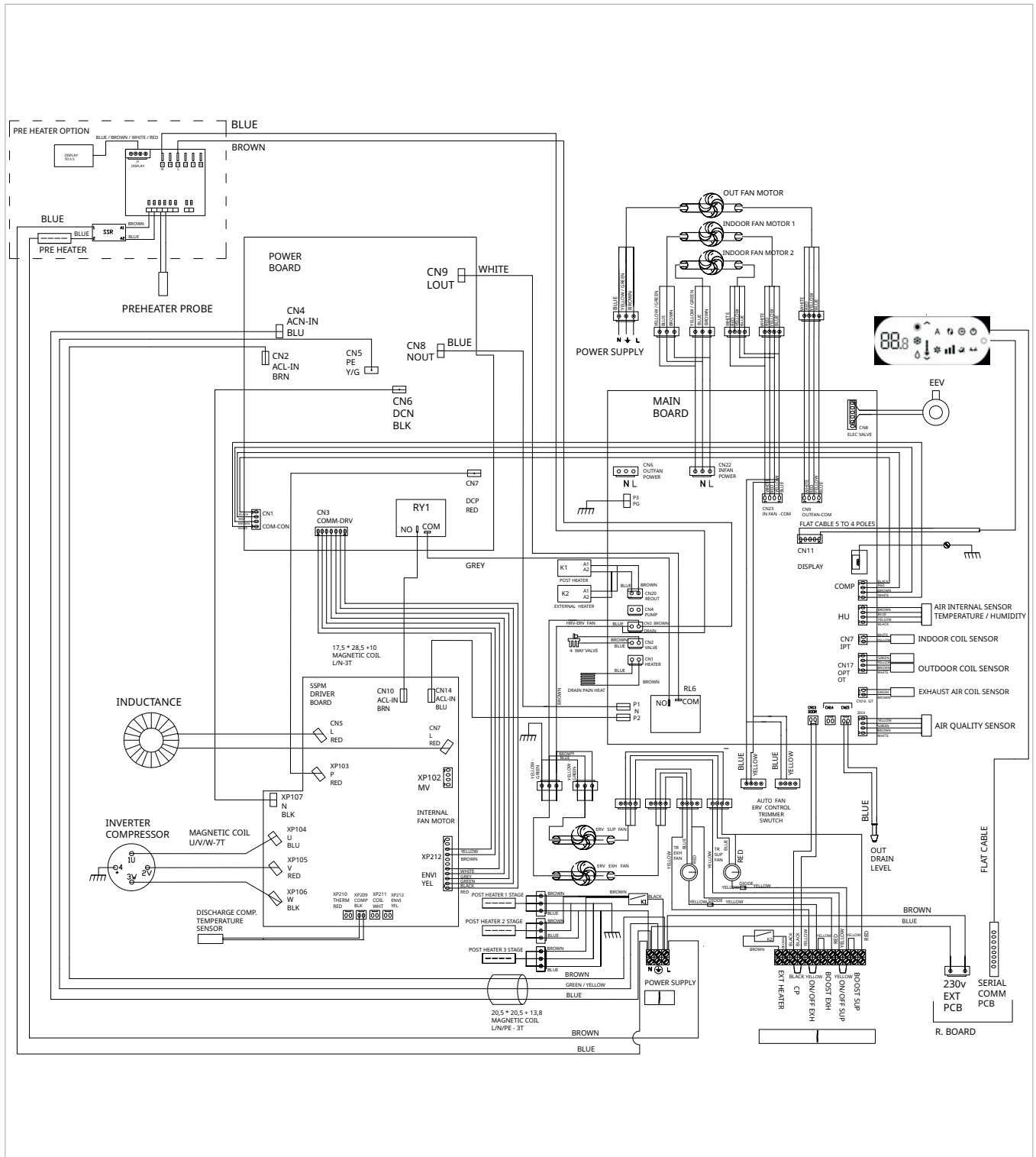

Digital inputs	
CN13	Presence contact for CP terminals
CN15	Drain alarm
Analog inputs	
HU	Internal air humidity and temperature probes
CN17 OT	External temperature probe
CN17 OPT	Condenser probe
CN7 IPT	Evaporator probe
CN16 GT	Exhaust air coil sensor
XP209	Compressor discharge temperature probe
Digital outputs	
CN1	Condensate collection tray resistance
CN2	Reversing valve summer/winter
CN3	Indoor air fan power supply VMC / External air fan power supply VMC
CN20	External heater / Post-heater
CN22	Power supply for indoor air supply fans
RL6	Compressor relay
Analog outputs	
CN23	0-10V control signal for indoor air supply fans
CN9	0-10V control signal for general air extraction fan
CN11	Display / Control panel

Connection terminal board

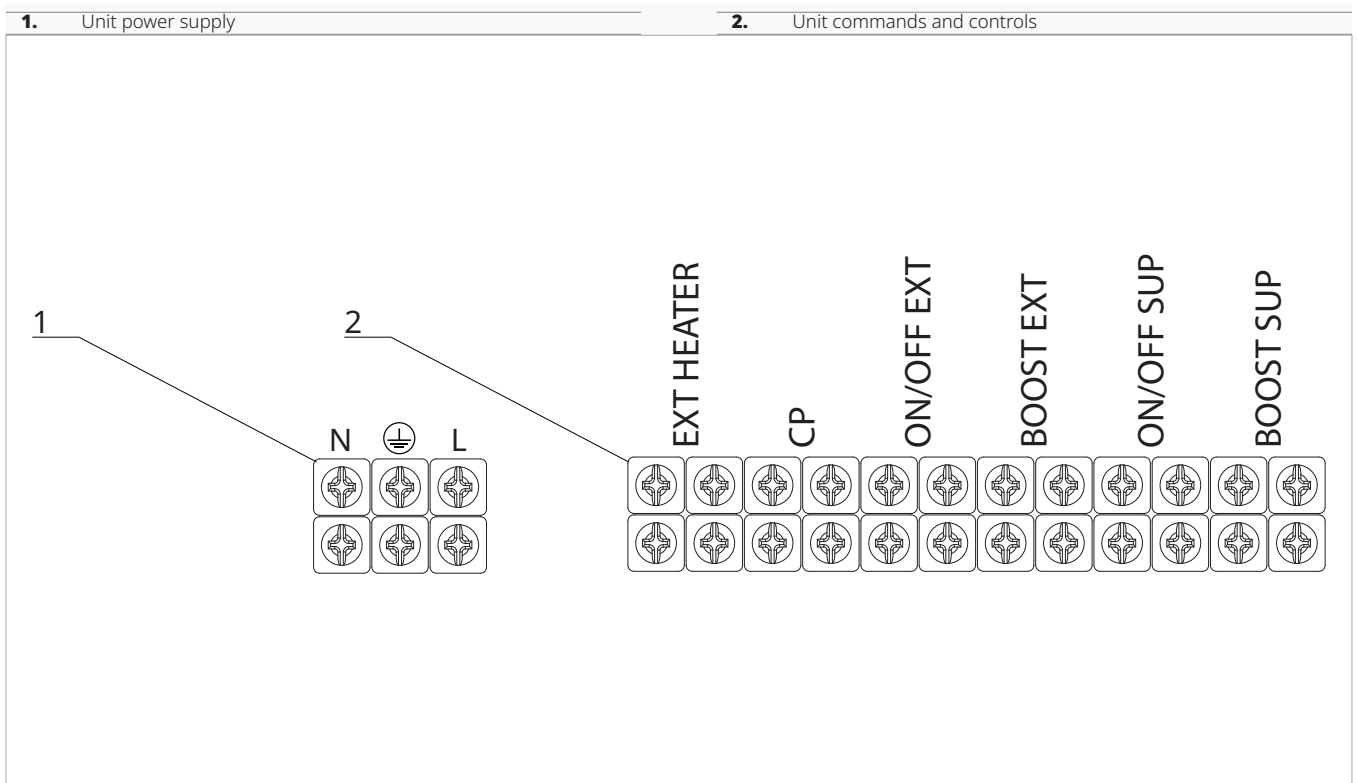

Connections to be made by the customer

EXT HEATER	External electric resistances connection	Contact closed - Resistances ON
CP	Unit activation ON/OFF remote	Contact closed - Unit ON

Connections to be made by the customer		
ON/OFF EXH	Exhaust fan activation	Contact closed - Fan ON
BOOST EXH	Exhaust fan booster function	Contact closed - Booster ON
ON/OFF SUP	Supply fan activation	Contact closed - Fan ON
BOOST SUP	Supply fan booster function	Contact closed - Booster ON

EXT HEATER connection

An external device can be connected through this contact. The device is activated in parallel with the post-heating resistors of the unit

Operation

When the unit requires activation of the supplementary electric resistors, the EXT HEATER contact closes.

The contact can withstand a maximum voltage of 230 V and a maximum current of 10 A.

On - Off remote connection

Through this contact it is possible to connect an external device which inhibits the operation of the appliance, such as:

- Remote On - Off (on board)

Operation

When the contact connected to the CP input is closed, all units are switched off.

When a button is pressed on the display, the symbol  flashes

- ⊖ It is forbidden to connect the CP input in parallel with other electronic boards. In this case, use separate contacts.

ON/OFF EXH connection

This contact allows activation or deactivation of the extraction electric fan of the HRV section.

Operation

Closing the contact activates the extraction electric fan of the HRV section.

The unit is supplied with a jumper that keeps the fan operation enabled

BOOST EXH connection

This contact allows activation of the booster function for the extraction electric fan of the HRV section.

Operation

Closing the contact activates the booster function.

The extraction electric fan of the HRV section operates at maximum speed until the contact reopens.

ON/OFF SUP connection

This contact allows activation or deactivation of the supply electric fan of the HRV section.

Operation

Closing the contact activates the supply electric fan of the HRV section.

The unit is supplied with a jumper that keeps the fan operation enabled.

BOOST SUP connection

This contact allows activation of the booster function for the supply electric fan of the HRV section

Operation

Closing the contact activates the booster function.

The supply electric fan of the HRV section operates at maximum speed until the contact reopens.

5. ON-BOARD DISPLAY

5.1 Interface

General switch-on

To be able to control the appliance using the remote control or the touch display:

- ▶ insert the power plug of the appliance into the power outlet of the installation or turn on the main switch provided on the power line

Once the operation is performed, through pressing the symbols on the touch screen display it will be possible to manage the operation of the system.

To activate the device

- ▶ press and hold the button 

The display switches on

The set point is shown on the three digits of display

88.8

- ⚠ The control system of the device has a memory, so all the settings will not be lost in case of power outage or shutdown, except for the ventilation. The button in question is used to activate and deactivate the device for short periods.

- ⚠ In case of prolonged shutdown of the device, it should be deactivated by switching off the main power switch or unplugging it from the power outlet.

Description

The unit is controlled through the built-in Wi-Fi panel and the provided infrared remote control.







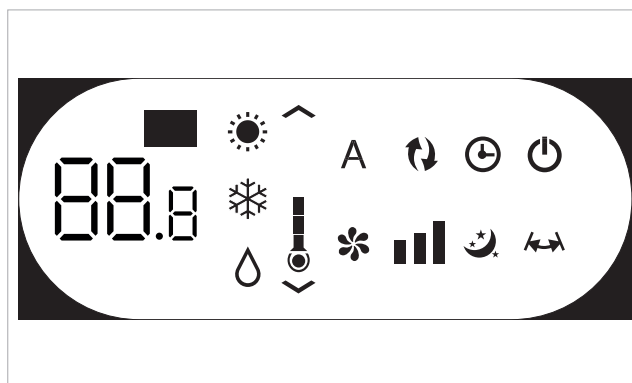







The onboard display allows you to:

- view the operating status
- view any alarms
- select the different functions by pressing the various symbols

Display





Related keys and functions

	Indicates the set point
	Increases the set temperature
	Decreases the set temperature
	Allows you to activate or put the appliance in stand-by
	Function not used
	Allows the function in cooling mode only
	Function in dehumidification mode only.
	Allows the function in ventilation mode only
	Allows the function in heating mode only
	Nocturnal wellness key
	Air renewal button
	Allows control of the ventilation speed
	Allows you to set the timer function
	Digital thermometer 1÷7 red bars in winter and blue in summer

5.2 Main functions

Set the temperature

To set the room temperature

- ▶ press the keys   to increase or decrease the desired value
The value shown on the display changes

- ⚠ The temperature adjustment range is from 16 to 31°C, with a resolution of 0.5°C.

- ⚠ Avoid setting the temperature too low or too high, as it can be detrimental to health and also leads to unnecessary energy waste.

Operation in ventilation mode only

To select the ventilation operation

- ▶ press and hold the button  for approx. 2 seconds

The  symbol on the display indicates that the Ventilation function is activated

By using this function, the device only activates the fan and does not have any effect on the temperature or humidity of the ambient air.

It is possible to choose the fan speed.

Operation in cooling mode only

To select the cooling operation

- ▶ press and hold the button  for approx. 2 seconds

The  symbol on the display indicates that the Cooling function is activated

By using this function, the appliance dehumidifies and cools the environment.

When the setpoint is lower than the room temperature, the fan coil unit starts and begins to deliver cold air, maintaining the ventilation even when the setpoint is reached.

Operation in heating mode only

To select the heating operation

- ▶ press and hold the button  for approx. 2 seconds

The  symbol on the display indicates that the Heating function is activated

By using this function, the device heats the environment. With a setpoint higher than the room temperature, the fan coil unit starts and begins to deliver hot air.

- ⚠ The anti-freeze function is enabled by default. In the event that the ambient temperature drops below 6° C, the unit will automatically activate even in the shutdown mode to prevent freezing.

Set the fan speed

To select the ventilation speed

- ▶ hold down the button 

The  symbol varies according to the ventilation speed in the following sequence:

 Minimum

 Medium

 Maximum

 Automatic (visible by scrolling the 3 speed bars on the display)

- ⚠ The higher the fan speed set, the greater the performance of the appliance, but the lower its quietness.
- ⚠ By setting the automatic fan speed, the onboard micro-processor independently adjusts the speed, keeping it higher as the deviation between the detected room temperature and the set temperature increases. The speed is automatically reduced as the room temperature approaches the set temperature.
- ⚠ In Dehumidification mode or Night Comfort mode, the control of fan speed is disabled as the unit can only operate at the minimum speed.

Nocturnal operation

To select the nocturnal wellness operation



- ▶ press and hold the button  for approx. 2 seconds

The  symbol lit on the display indicates that the Nocturnal Wellness function is activated

- ⚠ The ventilation speed is automatically set to the minimum speed.
- ⚠ The set temperature varies automatically:
 - in heating mode, the set temperature decreases by 1°C after the first hour and by an additional degree in the second hour
 - in cooling mode, the set temperature increases by 1°C after the first hour and by an additional degree in the second hour
 - In both cases, after the second hour, the temperature setpoint will not be further altered, and after 6 hours, the unit will go into standby mode.
- ⚠ This function is not available for dehumidification-only and ventilation-only operation.
- ⚠ This function can be disabled at any time by pressing the button again.
- ⚠ If the Timer function is set simultaneously, the appliance will turn off when the set time expires.







Set the timer function

To set the timer function

- ▶ hold down the button  for 5 seconds
- The  symbol on the display indicates that the Timer function is activated

This function allows you to schedule the activation or deactivation of the appliance.



To program the activation of the appliance

- ▶ with the display off, press the  key for 5 seconds
- The  symbol on the display indicates that the Timer function is activated
- ▶ select with the arrows   the number of hours (from 1 to 24 h) after which the appliance will be switched on automatically
 - ▶ press the button again  to confirm the operation
- The display lights up completely, showing the settings (setpoint, active functions, etc.) that will be activated when the appliance is turned on automatically.
- ▶ press the button again  to confirm the operation



To program the device to turn off.

Set the key lock

To set the key lock

- ▶ press and hold the button  for approx. 10 seconds
- The display lights up entirely, showing the active settings, and the  flashes with a frequency of 1 second
- Any action is prevented from the user

To deselect the key lock



- ▶ press and hold the button  for approx. 10 seconds
The display lights up entirely, showing the active settings, and the  button remains fixed.

To deactivate/put the control unit in standby mode**To deactivate/put the control unit in standby mode**

- ▶ press and hold the button  for approx. 2 seconds
The control panel switches off

- ⚠ The control system of the appliance is equipped with memory, so all settings will be retained in case of power loss or shutdown (except for ventilation).
- ⚠ In stand-by mode, the control system ensures anti-freeze protection.
- ⚠ In case of extended shutdown of the appliance, it should be deactivated by disconnecting the main switch or removing the plug from the power outlet.



Heater type configuration**To configure the heater type**

- ▶ press and hold the button  for about 5 seconds
- ▶ press and hold the button  for about 2 seconds to scroll through the available modes
- ▶ stay on the desired mode without pressing any other button to automatically confirm the selection



- FH: activates the heater if the set point is not reached within 20 minutes (default)
- Fo: mode that must not be selected under any circumstances
- rE: activates the heater; if the outdoor temperature drops to -20 °C, the compressor is deactivated and only the heater remains active

- ⚠ **Never select the "Fo" mode. Improper use of this option can cause operational damage to the appliance.**

Screen brightness adjustment**To adjust screen brightness**

- ▶ press and hold the  button until the word En appears on the display
- ▶ press the  button again until ds appears, to keep brightness always at maximum
- ▶ do not press any button for a few seconds

Hotel function



- ▶ press and hold  until ds appears on the display
- ▶ press  again until En appears
- ▶ do not press any button for a few seconds

- ⚠ The Dehumidification and Automatic functions are disabled (only ventilation, heating and cooling remain active) and the adjustable temperature range is: 22°C - 28°C in cooling and 16°C - 24°C in heating

°F/°C switching

- ▶ press and hold  until the temperature unit changes

Connectivity expansion module**To disable and restore the WiFi module**

- ▶ press and hold the  button for about 15 seconds
- ▶ check that the word On appears (enables WiFi operation)
- ▶ press  again until the word rSt appears (resets WiFi settings)
- ▶ press  again until the word OFF appears (disables WiFi operation)

5.3 Warnings**Alarm display on the onboard display**

- ⚠ In case of an appliance malfunction, an alarm code is displayed on the screen.
- ⚠ In case of an alarm, the appliance still maintains some active functions.
 - ▶ E1 RH sensor error
The input does not detect serial communication with the intervention sensor.
 - ▶ E2 IPT sensor error
The input detects a resistance value (ohm) outside the expected range or a short circuit.
 - ▶ E3 OT sensor error
The input detects a resistance value (ohm) outside the expected range or a short circuit.
 - ▶ E4 OPT sensor error
The input detects a resistance value (ohm) outside the expected range or a short circuit.

- ▶ E5 Infan fan error
Internal electric fan speed is out of the allowable range.
- ▶ E6 Outfan fan error
External electric fan speed is out of the allowable range.
- ▶ E7 Driver communication error
- ▶ E8 Compressor discharge sensor error
- ▶ OF Float error
High-level float switch triggered in the condensate collection tray.
- ▶ CP Presence contact error
The unit only operates with the CP contact closed.

Problem diagnosis

It is important for the user to be able to distinguish between any malfunctions or functional anomalies and the expected behavior of the device during its normal operation.

Most common issues can be easily resolved by the user through simple operations, while for some alarms displayed on the screen, it is necessary to contact the Customer Support Service.

⚠ Any attempt of repair carried out by unauthorized personnel immediately voids any form of warranty.

6. M7 SERIES CONTROLS EEB733 MODBUS

6.1 Interface

Description

The M7 series LED electronic control panels with touch interface for wall installation allow:

- adjustment of the room temperature
- management of the main functions of the device
- temperature and humidity measurement
- adjustment of the fan speed

They are equipped with:

- internal memory with data storage even in the event of abnormal shutdown or power failure

- ⚠ 20 seconds after the last action, the panel brightness is reduced, and only the room temperature is shown on the display.
- ⚠ Maximum brightness is restored when any button is pressed.
- ⚠ It is mandatory to disable the connectivity expansion module (Wi-Fi) from the Touchpad. See paragraph "Connectivity expansion module" *p. 31*. If using the app to control the unit, it must be paired with a wall control series M/ code EFB733II.

Display

Statuses and alarms displayed.

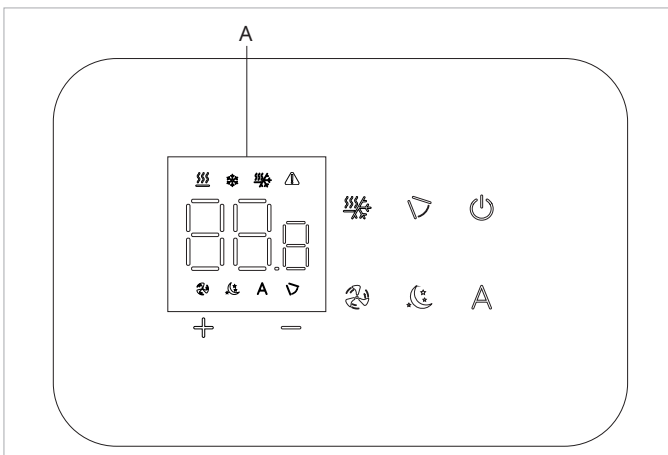

A	Display area
	Displays room temperature / setpoint
	Alarm signal
	HRV unit active
	Fan speed selection
	Automatic season mode
	Cooling operation mode active
	Heating operation mode active
	Automatic modulation of fans and compressor
	Night function active

Key functions

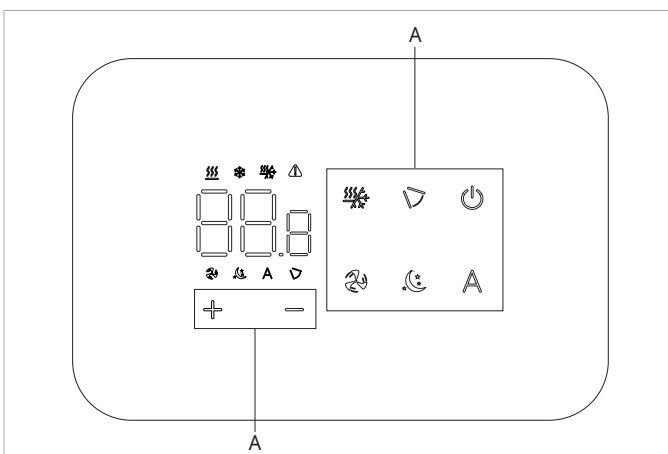

A	Keypad area
	Increases the set temperature
	Decreases the set temperature
	Allows activating or deactivating the unit
	Enables or disables the HRV unit
	Allows you to control the ventilation speed
	Allows selection of the operation mode between Heating and Cooling
	Automatic modulation of fans and compressor
	Enables the Night function

6.2 Installation

Description

The wall remote control is an electronic LED thermostat with a touch interface, capable of controlling multiple devices equipped with the same electronic board. It is equipped with a temperature and humidity sensor.

Mounting

- ⚠ The control panel for wall control must be installed inside a 503 electrical box.
- ⚠ Before proceeding with the installation of the wall control panel, it is necessary to prepare the wall for housing the 503 electrical box.
- ⚠ Make sure that:
 - the wall supports the weight of the appliance
 - the section of wall does not contain pipes or electrical lines
 - the functionality of load-bearing elements is not compromised

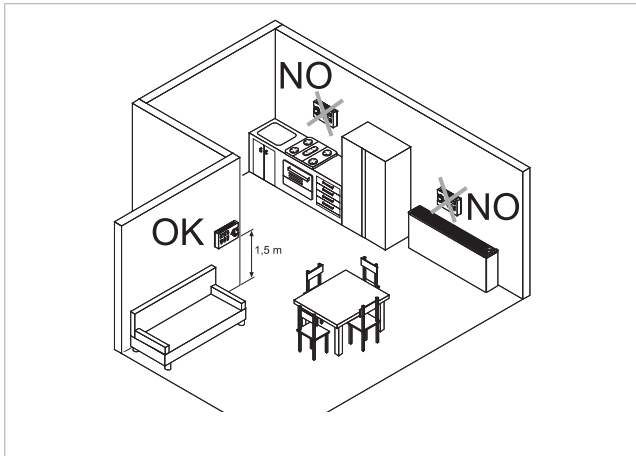

The wall control must be installed:

- on the outside walls
- at a height of approx. 1.5 m above the floor
- ⚠ If the control is located in an area used by people with reduced physical capabilities, refer to local regulations.
- away from doors and windows
- away from heat sources such as radiators, fan coils, cookers, direct sunlight
- ⚠ The wall control is supplied already assembled in the package.

1. Control base
2. Wall control command

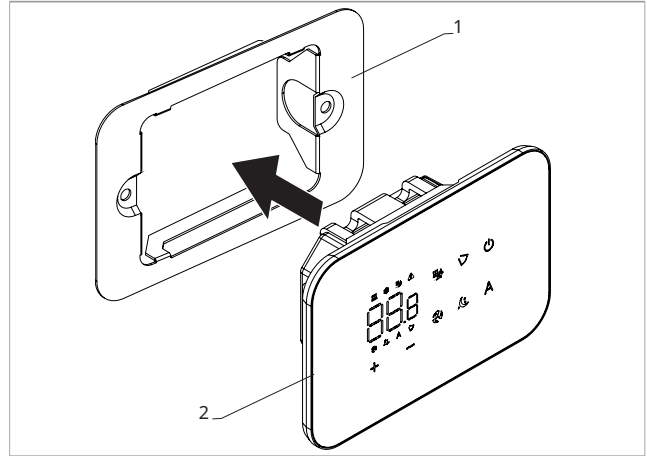

Before mounting on the wall:

- ▶ Separate the control base from the control panel

1. Fixing screws
2. Control base
3. Holes for fixing to the electrical box
4. Electrical box

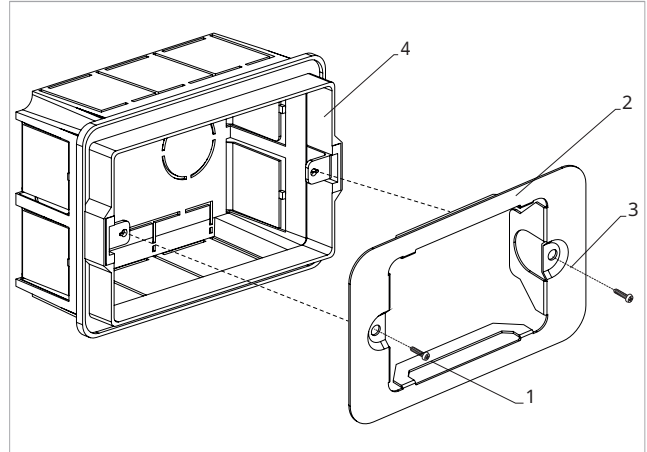

For wall mounting of the control panel:

- ▶ Fix the control base to the 503 electrical box with screws
- ▶ Make the connections
- ⚠ It is mandatory to use ferrules on all conductors, both on the board side and on the flush-mounted terminal block side, in order to prevent permanent damage to the equipment.

To avoid incorrect temperature measurement:

- ▶ seal the cable entry points to prevent air from passing through
- ▶ seal all openings present in the box or the wall
- ⚠ Proper sealing ensures the correct functioning of the sensor and the reliability of the temperature control.
- ⚠ Before making the connections, check that the terminal block of the command is on the right side.

1. Electrical box
2. Control base
3. Wall control command

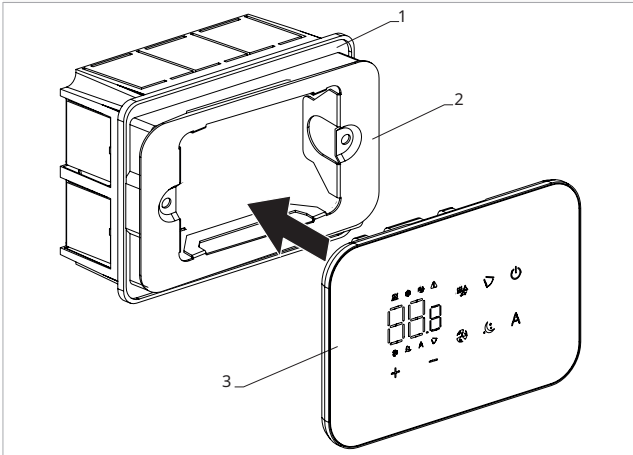

- ▶ reposition the control panel onto the base
- ⚠ Be careful not to crush the wires when closing the control.

6.3 Connection diagram

Connection diagram for switching from internal display to M7

To connect the remote control panel, disconnect the display installed on the appliance and connect the remote panel in its place using the dedicated connector for M7

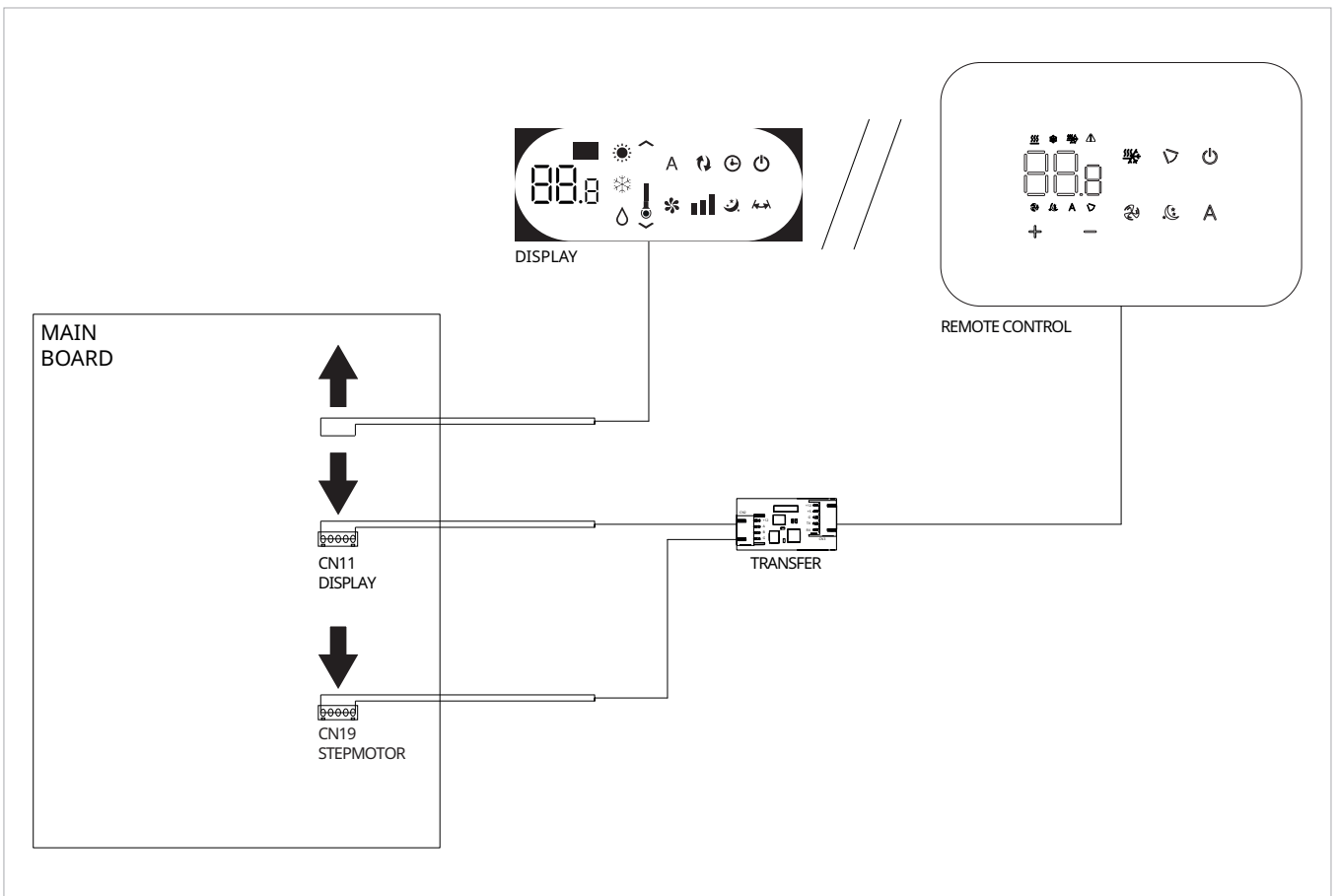

Wiring diagram with M7

Connect the remote control panel following the supplied electrical diagram

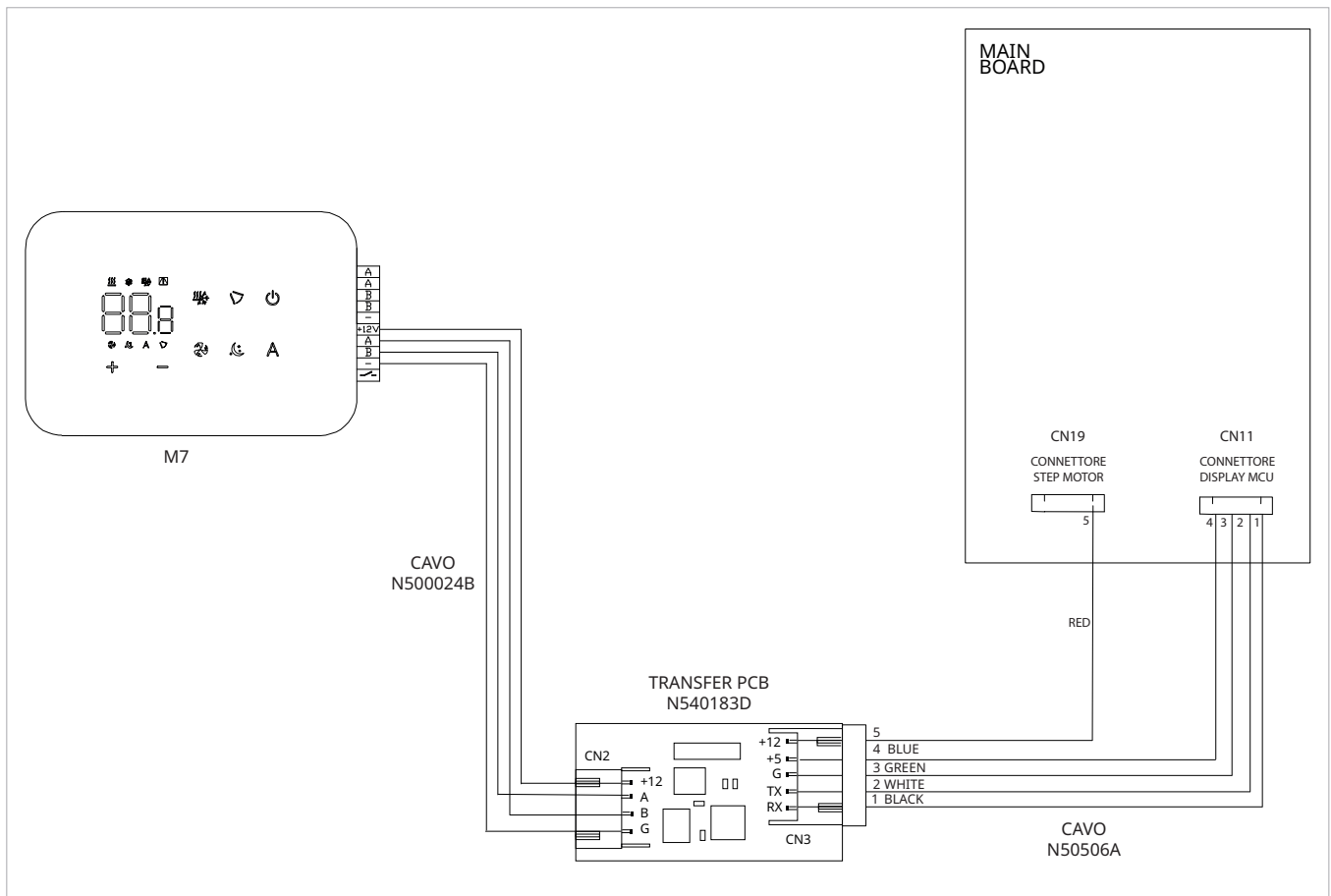

⚠ Connect the CP directly to the machine's internal terminal block, not to the M7 panel.

6.4 Connections

Preliminary warnings

- ⚠ **For safety warnings, requirements, checks and procedures related to the refrigerant, refer to the section "Information related to the refrigerant".**
- ⚠ The terminals for connecting the control panel and the CP presence contact are inserted in a plastic bag and placed on the inside of the electrical box cover.
- ⚠ It is mandatory to use ferrules on all conductors, both on the board side and on the flush-mounted terminal block side, in order to prevent permanent damage to the equipment.

1. Terminals

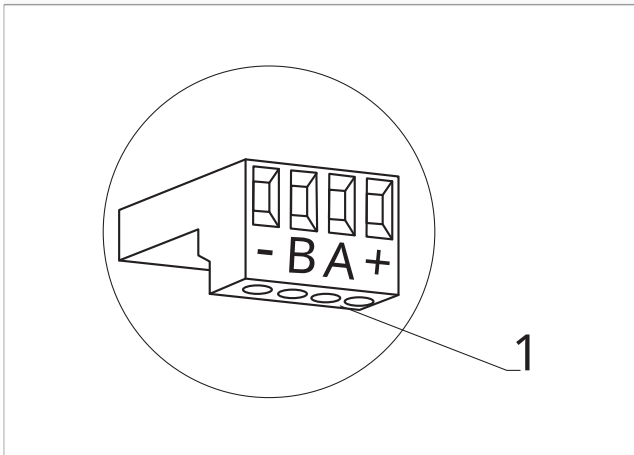

The terminals accept:

- rigid or flexible cables with a cross-section from 0.2 to 1 mm²
- rigid or flexible cables with a cross-section of 0.5 mm² if connecting two conductors in the same terminal
- rigid or flexible cables with a maximum cross-section of 0.75 mm² if equipped with a plastic collar ferrule

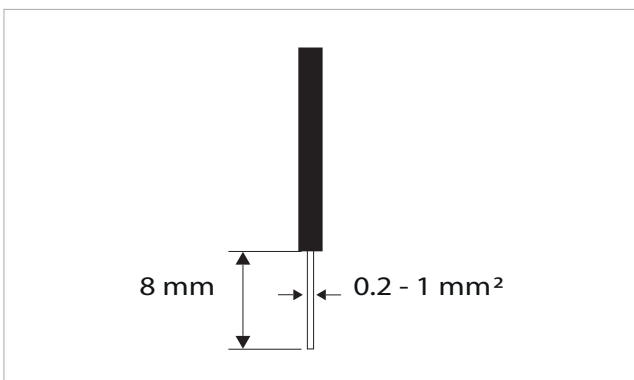

To connect the cables:

- ▶ strip 8 mm
- ▶ in the case of a rigid cable, insert it easily
- ▶ in the case of a flexible cable, use needle-nose pliers to assist
- ▶ push the cables in completely
- ▶ verify correct attachment by pulling them slightly

Remote control

- ⚠ The wall control panel must be ordered separately.
- Position of the terminal blocks:**

1. Terminal block (Panel rear view)

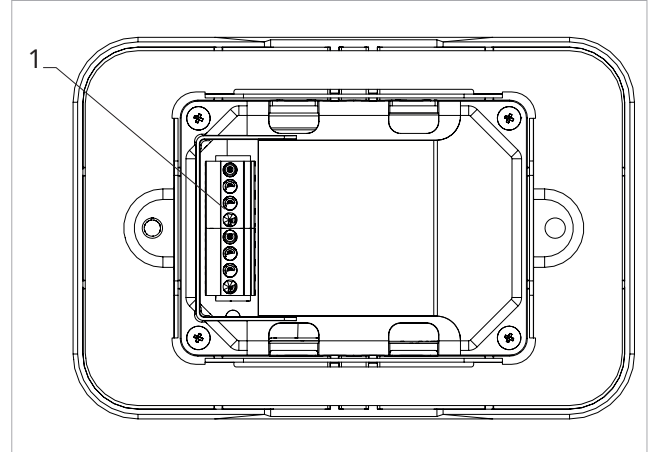

To make the connections:

- ▶ connect the cables following the "Connection diagram" p. 35
- ▶ connect the ModBus serial connection cables to terminals A and B

CP presence contact

Through this contact it is possible to connect an external device which inhibits the operation of the appliance, such as:

- window open contact
- remote on/off
- Presence infrared sensor
- Enabling badge

Operation

The contact is normally open.

- ▶ when the CP contact, connected to a clean, non-live contact, is closed, the device goes into stand-by
CP is displayed on the screen.

- ⊖ It is forbidden to connect the CP input in parallel with other electronic boards. Use separate contacts.
- ⚠ **Connect the CP directly to the machine's internal terminal block, not to the M7 panel.**

RS485 serial connection

The wall remote control can be connected via an RS485 line.

The appliance must be equipped with an electronic board suitable for remote control.

For the connection:

- ▶ follow the connection diagram
- ▶ connect following the A and B indications
- ⚠ Use a shielded two-core cable suitable for serial RS485 connection with a minimum cross-section of 0.35 mm².





- ⚠ Keep the bipolar cable at least 50 mm away from the power supply cables.
- ⚠ Route in such a way as to minimise the length of deviations.

- ⚠ Terminate the line with a 120 Ω resistor between A and B.
- ⊖ Star connections are prohibited.



6.5 Functions

Basic menu

To access the basic menu

- ▶ From display off, hold the button  for 10 seconds
The device turns on and  appears
- ▶ Hold until the indication  appears
- ▶ Release the button 
The symbol  appears

To navigate within the menu

- ▶ Use the icons  

To select menu items and confirm changes

- ▶ Press the icon 
Confirming the change moves to the next item.

To exit the menu

- ▶ press the icon  for 10 seconds
- ▶ or wait 30 seconds for automatic shutdown

- ⚠ After a period of 30 seconds from the last action, the display turns off and the changes made are automatically saved.

Menu items

ur: Value read from the humidity sensor

CF: Scale

ub: Buzzer volume

uu: Not used

uP: Not used

ho: Hotel Mode



PP: Air flow adjustment parameter setting

HC: Heating and Cooling options configuration

Ht: Heater type configuration





Scale

To change the temperature unit

- ▶ select 
- ▶ Press  to change settings
- ▶ Select °C or °F
- ▶ Press  to confirm
By default, the temperature unit is °C.

Adjust volume

To change the control volume

- ▶ select 
- ▶ Press  to change settings
- ▶ Increase or decrease the value with the icons  
- ▶ Press  to confirm
By default, the volume is set to 5.

- ⚠ The volume changes after confirming the modification.

Hotel mode

To set the Hotel mode





- ▶ select 
- ▶ select YES to activate Hotel mode
- ▶ select NO to deactivate Hotel mode
By default, the appliance is set to NO.

When Hotel mode is activated:

- the Automatic function of the fans is deactivated
- only Heating and Cooling functions remain active
- the temperature adjustment range is reduced: Cooling can be set from 22 °C to 28 °C, Heating can be set from 16 °C to 24 °C

Air flow adjustment parameter setting

To set the air flow (indoor air supply and external exhaust side)

- ▶ select 
- ▶ Press  to change settings
- ▶ use the  and  buttons to select the desired program
- ▶ Press  to confirm

Program	Description	Indoor Side	Outdoor Side
P1	IN LOW / OUT LOW	LOW	LOW
P2	IN MED / OUT LOW	MED	LOW
P3	IN HIGH / OUT LOW	HIGH	LOW
P4	IN LOW / OUT MED	LOW	MED
P5	IN MED / OUT MED	MED	MED
P6	IN HIGH / OUT MED	HIGH	MED
P7	IN LOW / OUT HIGH	LOW	HIGH
P8	IN HIGH / OUT HIGH	HIGH	HIGH

Heating and Cooling options configuration

⚠ It is possible to disable the Heating or Cooling function by setting the appliance to Heating only or Cooling only mode.

To set Heating only or Cooling only mode

- ▶ select 
 - ▶ select hc to set Heating and Cooling mode
 - ▶ select ho to set Heating only mode
 - ▶ select co to set Cooling only mode
- By default, the appliance is set to hc.*

Heater type configuration

To configure the heater type







- ▶ select 
- ▶ select NO to set the resistor in Fh mode
Fh: activates the resistor if the set point is not reached within 20 minutes (default)
- ▶ select YS to enable the resistor in rE mode
rE: the resistor activates with the compressor if the set-point is 5 °C different from the room temperature; with external temperature of -20 °C the compressor turns off and only the resistor remains active.

Display alarms on the wall control panel

⚠ In case of an alarm, the appliance still maintains some active functions.

⚠ To indicate alarms on the control panel for wall control, the fixed symbol  is displayed.

To view errors on the wall control panel

- ▶ access the basic menu
- ▶ press 
Appears 
- ▶ press 
- ▶ press 
Appears 
- ▶ press  to access the menu
Subsequently, the number assigned to the fan coil appears and then the error is displayed.

Displayed alarms

- ▶ E1 RH sensor error
The input does not detect serial communication with the intervention sensor.
- ▶ E2 IPT sensor error
The input detects a resistance value (ohm) outside the expected range or a short circuit.
- ▶ E3 OT sensor error
The input detects a resistance value (ohm) outside the expected range or a short circuit.
- ▶ E4 OPT sensor error
The input detects a resistance value (ohm) outside the expected range or a short circuit.
- ▶ E5 Infan fan error
Internal electric fan speed is out of the allowable range.
- ▶ E6 Outfan fan error
External electric fan speed is out of the allowable range.

- ▶ E7 Driver communication
- ▶ E8 Communication error between display and MCU
- ▶ Communication error between wall control panel and electronic board
- ▶ OF Float error
High-level float switch triggered in the condensate collection tray.
- ▶ CP Presence contact error
The unit only operates with the CP contact closed.
- ▶ Alr Compressor discharge sensor error

7. M7 SERIES CONTROLS EFB733 WI-FI

7.1 Interface

Description

The M7 series LED electronic control panels with touch interface for wall installation allow:

- adjustment of the room temperature
- management of the main functions of the device
- temperature and humidity measurement
- adjustment of the fan speed

They are equipped with:

- internal memory with data storage even in the event of abnormal shutdown or power failure
- ⚠ 20 seconds after the last action, the panel brightness is reduced, and only the room temperature is shown on the display.
- ⚠ Maximum brightness is restored when any button is pressed.
- ⚠ It is mandatory to disable the connectivity expansion module (Wi-Fi) from the Touchpad. See paragraph "Connectivity expansion module" *p. 31*

Display

Statuses and alarms displayed.

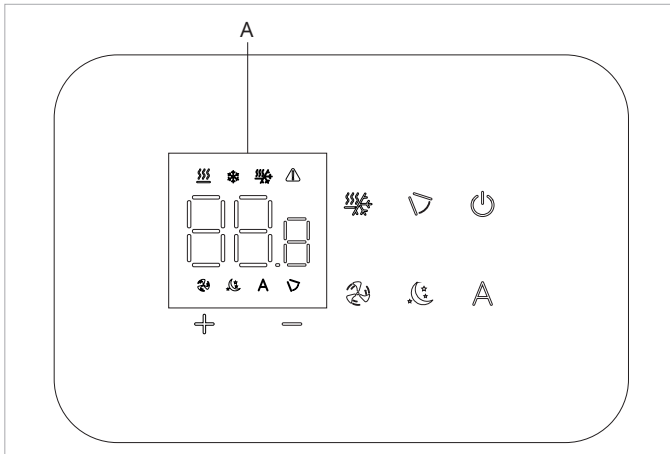

A	Display area
8888	Displays room temperature / setpoint
⚠	Alarm signal
🔄	HRV unit active
🌀	Fan speed selection
🌿	Automatic season mode
❄️	Cooling operation mode active
🔥	Heating operation mode active
⚙️	Automatic modulation of fans and compressor
🌙	Night function active

Key functions

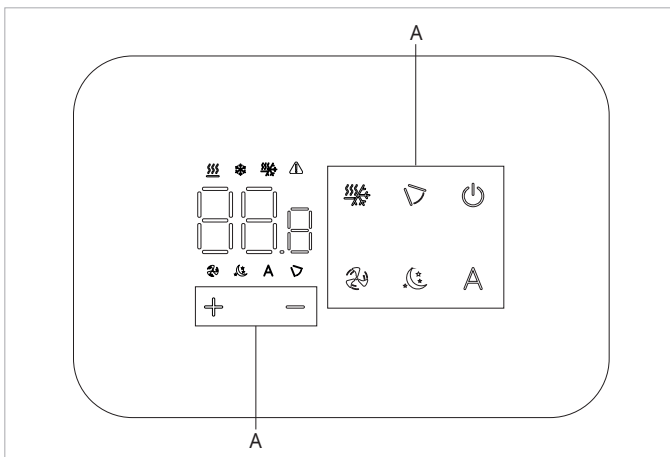

A	Keypad area
+	Increases the set temperature
-	Decreases the set temperature
🔥	Allows activating or deactivating the unit
🔄	Enables or disables the HRV unit
🌀	Allows you to control the ventilation speed
🌿	Allows selection of the operation mode between Heating and Cooling
⚙️	Automatic modulation of fans and compressor
🌙	Enables the Night function

7.2 Installation

Description

the wall control panel is an electronic LED thermostat with touch interface, with the ability to control multiple appliances equipped with the same electronic board. It features a temperature and humidity sensor.

- ⚠ The command can control up to 16 devices.
- ⚠ The Innova app is available for controlling the following control.

Mounting

- ⚠ The control panel for wall control must be installed inside a 503 electrical box.
- ⚠ Before proceeding with the installation of the wall control panel, it is necessary to prepare the wall for housing the 503 electrical box.
- ⚠ Make sure that:
 - the wall supports the weight of the appliance
 - the section of wall does not contain pipes or electrical lines
 - the functionality of load-bearing elements is not compromised

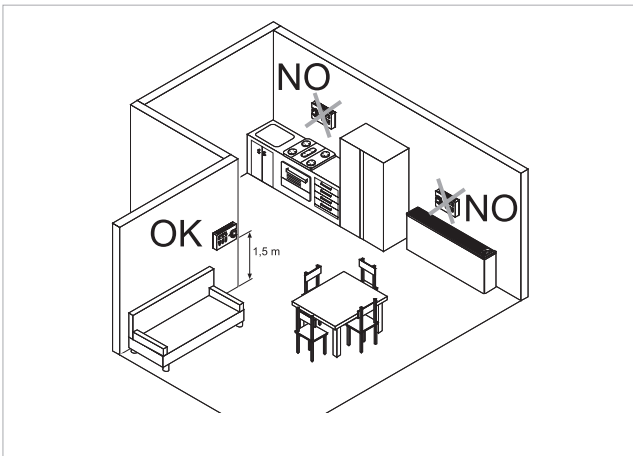

The wall control must be installed:

- on the outside walls
- at a height of approx. 1.5 m above the floor
- ⚠ If the control is located in an area used by people with reduced physical capabilities, refer to local regulations.
- away from doors and windows
- away from heat sources such as radiators, fan coils, cookers, direct sunlight
- ⚠ The wall control is supplied already assembled in the package.

- | | |
|----|----------------------|
| 1. | Control base |
| 2. | Wall control command |

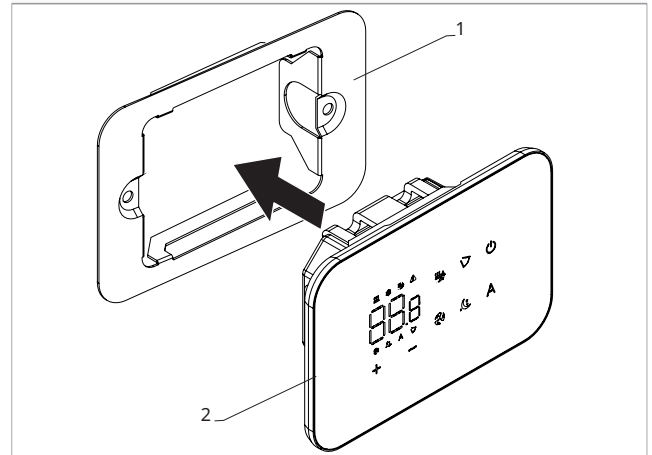

Before mounting on the wall:

- ▶ Separate the control base from the control panel

- | | |
|----|--|
| 1. | Fixing screws |
| 2. | Control base |
| 3. | Holes for fixing to the electrical box |
| 4. | Electrical box |

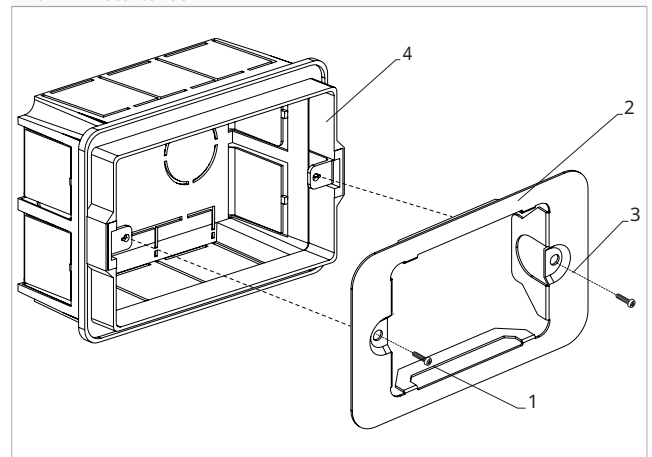

For wall mounting of the control panel:

- ▶ Fix the control base to the 503 electrical box with screws
- ▶ Make the connections

- ⚠ It is mandatory to use ferrules on all conductors, both on the board side and on the flush-mounted terminal block side, in order to prevent permanent damage to the equipment.

To avoid incorrect temperature measurement:

- ▶ seal the cable entry points to prevent air from passing through
- ▶ seal all openings present in the box or the wall
- ⚠ Proper sealing ensures the correct functioning of the sensor and the reliability of the temperature control.
- ⚠ Before making the connections, check that the terminal block of the command is on the right side.

1. Electrical box
2. Control base
3. Wall control command

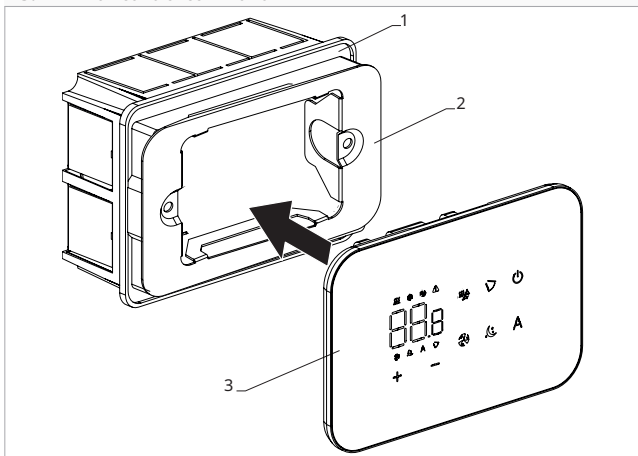

- ▶ reposition the control panel onto the base
- ⚠ Be careful not to crush the wires when closing the control.

7.3 Connection diagram

Connection diagram for switching from internal display to M7

To connect the remote control panel, disconnect the display installed on the appliance and connect the remote panel in its place using the dedicated connector for M7

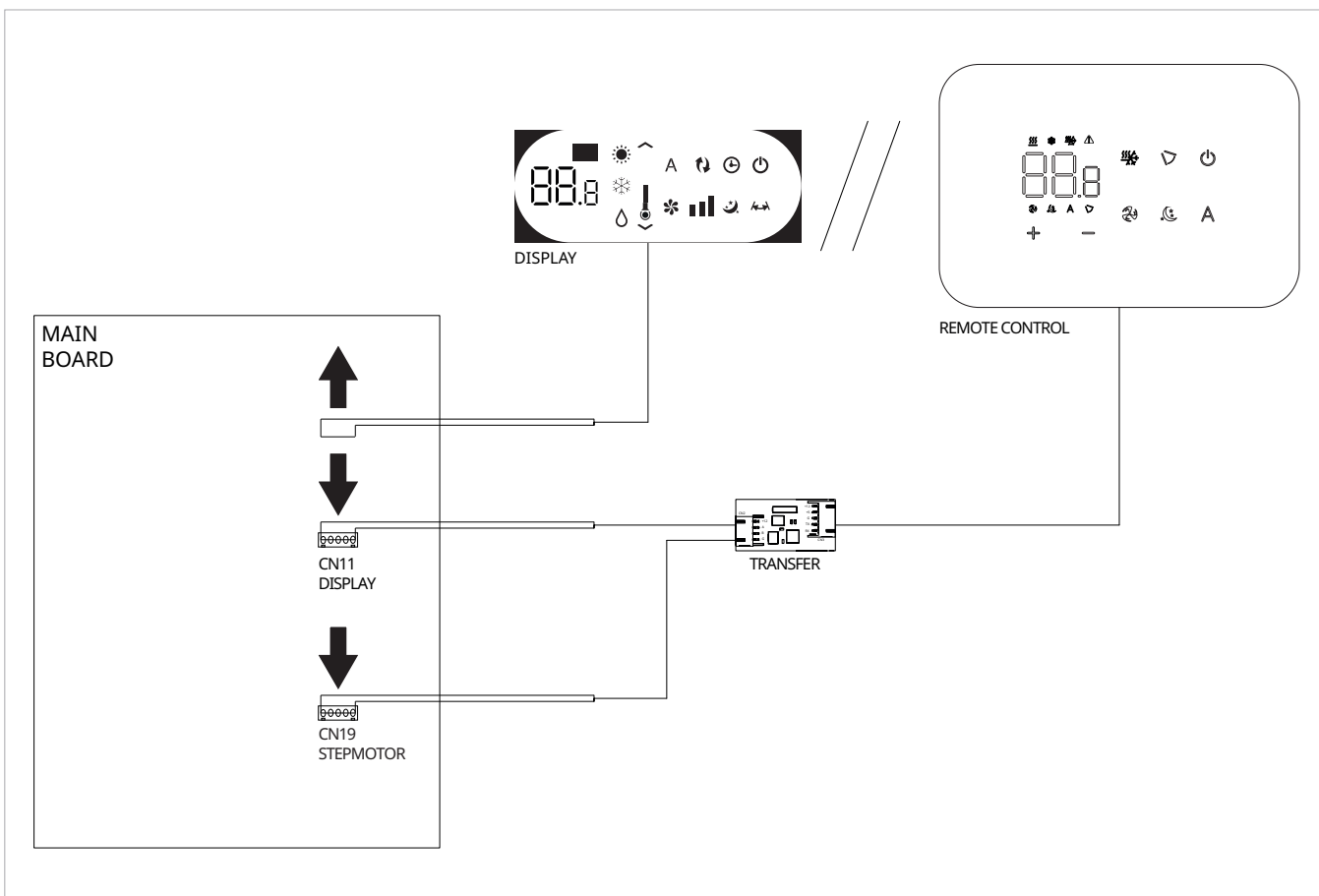

Wiring diagram with M7

Connect the remote control panel following the supplied electrical diagram

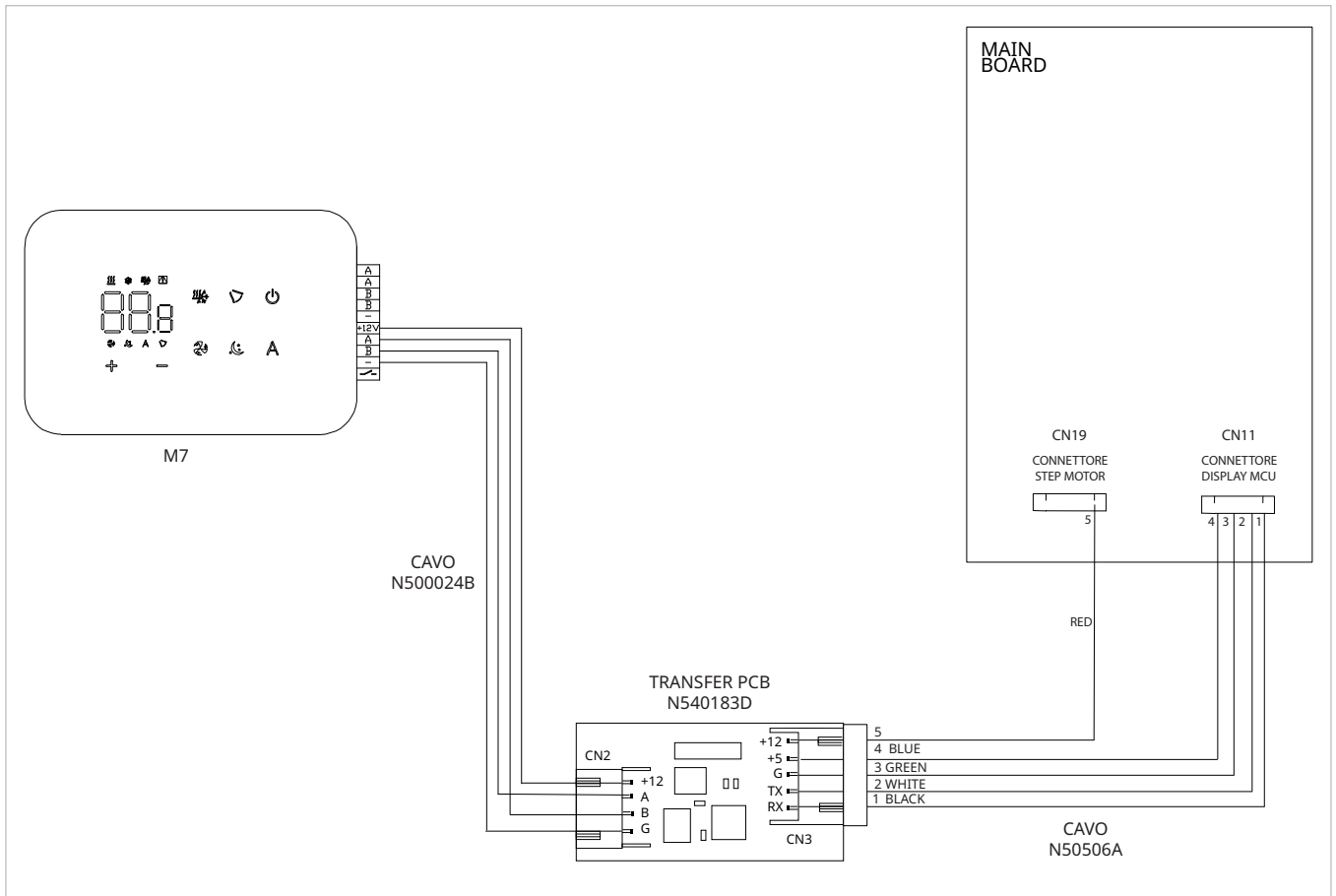

⚠ **Connect the CP directly to the machine's internal terminal block, not to the M7 panel.**

7.4 Connections

Preliminary warnings

- ⚠ **For safety warnings, requirements, checks and procedures related to the refrigerant, refer to the section "Information related to the refrigerant".**
- ⚠ The terminals for connecting the control panel and the CP presence contact are inserted in a plastic bag and placed on the inside of the electrical box cover.
- ⚠ It is mandatory to use ferrules on all conductors, both on the board side and on the flush-mounted terminal block side, in order to prevent permanent damage to the equipment.

1. Terminals

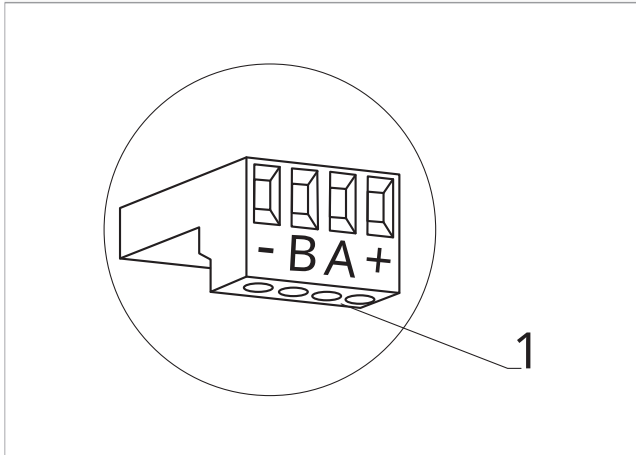

The terminals accept:

- rigid or flexible cables with a cross-section from 0.2 to 1 mm²
- rigid or flexible cables with a cross-section of 0.5 mm² if connecting two conductors in the same terminal
- rigid or flexible cables with a maximum cross-section of 0.75 mm² if equipped with a plastic collar ferrule

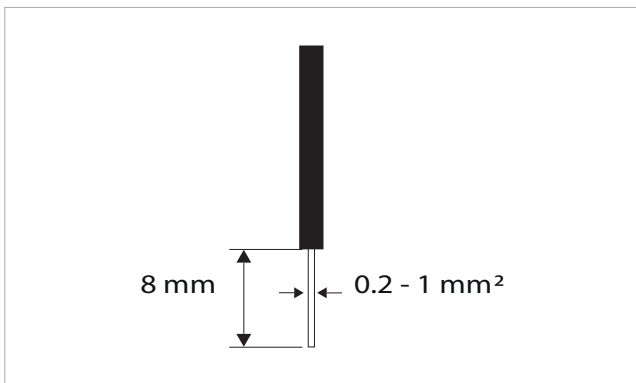

To connect the cables:

- ▶ strip 8 mm
- ▶ in the case of a rigid cable, insert it easily
- ▶ in the case of a flexible cable, use needle-nose pliers to assist
- ▶ push the cables in completely
- ▶ verify correct attachment by pulling them slightly

Remote control

- ⚠ The wall control panel must be ordered separately.
- Position of the terminal blocks:**

1. Terminal block (Panel rear view)

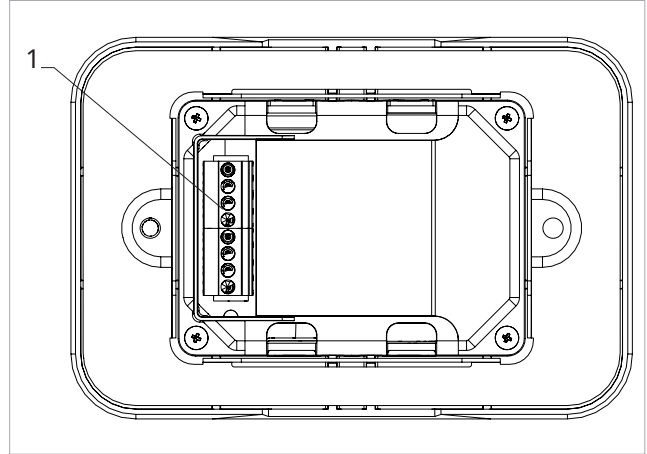

To make connections between the wall control panel and the board:

- ▶ connect the cables following the "Connection diagram" p. 35
- ▶ connect the ModBus serial connection cables to terminals A and B

CP presence contact

Through this CP contact present on the terminal block inside the electrical panel on board the unit, it is possible to connect an external device that inhibits the operation of the appliance such as:

- window open contact
- remote on/off
- Presence infrared sensor
- Enabling badge

Operation





The contact is normally open.

- ▶ when the CP contact, connected to a clean, non-live contact, is closed, the device goes into stand-by
- ⊖ It is forbidden to connect the CP input in parallel with other electronic boards. Use separate contacts.
- ⚠ **Do not connect the CP to the M7 panel.**



7.5 Functions

Basic menu

To access the basic menu

- ▶ From display off, hold the button  for 10 seconds
The device turns on and  appears
- ▶ Hold until the indication  appears
- ▶ Release the button 
The symbol  appears

To navigate within the menu

- ▶ Use the icons  

To select menu items and confirm changes

- ▶ Press the icon 
Confirming the change moves to the next item.

To exit the menu

- ▶ press the icon  for 10 seconds
- ▶ or wait 30 seconds for automatic shutdown

⚠ After a period of 30 seconds from the last action, the display turns off and the changes made are automatically saved.

Menu items

ur: Value read from the humidity sensor

CF: Scale

ub: Buzzer volume

uu: Wi-Fi Reset

ho: Hotel Mode



PP: Air flow adjustment parameter setting

HC: Heating and Cooling options configuration

Ht: Heater type configuration





Scale

To change the temperature unit

- ▶ select 
- ▶ Press  to change settings
- ▶ Select °C or °F
- ▶ Press  to confirm
By default, the temperature unit is °C.

Adjust volume









To change the control volume

- ▶ select 
- ▶ Press  to change settings
- ▶ Increase or decrease the value with the icons  
- ▶ Press  to confirm
By default, the volume is set to 5.

⚠ The volume changes after confirming the modification.









Reset Wi-Fi

To reset Wi-Fi credentials and restore the device to its original configuration

- ▶ select 
- ▶ Press  to change settings
- ▶ use the icons  and  sequentially
Appears 
- ▶ press 
 appears to reset Wi-Fi credentials.
- ▶ Press  to confirm
The credentials have been reset.

Activate Wi-Fi

To activate Wi-Fi

- ▶ select 
- ▶ Press  to change settings
- ▶ use the icons  and  sequentially
Appears 
- ▶ press 
 appears to enable Wi-Fi pairing.
- ▶ Press  to confirm

⚠ The device remains visible to the App for the first 15 minutes after appliance startup

Hotel mode





To set the Hotel mode

- ▶ select 
- ▶ select YES to activate Hotel mode
- ▶ select NO to deactivate Hotel mode
By default, the appliance is set to NO.

When Hotel mode is activated:

- the Automatic function of the fans is deactivated
- only Heating and Cooling functions remain active
- the temperature adjustment range is reduced: Cooling can be set from 22 °C to 28 °C, Heating can be set from 16 °C to 24 °C

Air flow adjustment parameter setting**To set the air flow (indoor air supply and external exhaust side)**

- ▶ select 
- ▶ Press  to change settings
- ▶ use the  and  buttons to select the desired program
- ▶ Press  to confirm

Program	Description	Indoor Side	Outdoor Side
P1	IN LOW / OUT LOW	LOW	LOW
P2	IN MED / OUT LOW	MED	LOW
P3	IN HIGH / OUT LOW	HIGH	LOW
P4	IN LOW / OUT MED	LOW	MED
P5	IN MED / OUT MED	MED	MED
P6	IN HIGH / OUT MED	HIGH	MED
P7	IN LOW / OUT HIGH	LOW	HIGH
P8	IN HIGH / OUT HIGH	HIGH	HIGH

Heating and Cooling options configuration

⚠ It is possible to disable the Heating or Cooling function by setting the appliance to Heating only or Cooling only mode.

To set Heating only or Cooling only mode

- ▶ select 
 - ▶ select hc to set Heating and Cooling mode
 - ▶ select ho to set Heating only mode
 - ▶ select co to set Cooling only mode
- By default, the appliance is set to hc.*



Heater type configuration**To configure the heater type**





- ▶ select 
- ▶ select NO to set the resistor in Fh mode
Fh: activates the resistor if the set point is not reached within 20 minutes (default)
- ▶ select YS to enable the resistor in rE mode
rE: the resistor activates with the compressor if the set-point is 5 °C different from the room temperature; with external temperature of -20 °C the compressor turns off and only the resistor remains active.

Display alarms on the wall control panel

- ⚠ In case of an alarm, the appliance still maintains some active functions.
- ⚠ To indicate alarms on the control panel for wall control, the fixed symbol  is displayed.

To view errors on the wall control panel

- ▶ access the basic menu
- ▶ press 
Appears .

- ▶ press 
- ▶ press 
Appears .
- ▶ press  to access the menu
Subsequently, the number assigned to the fan coil appears and then the error is displayed.

Displayed alarms

- ▶ E1 RH sensor error
The input does not detect serial communication with the intervention sensor.
- ▶ E2 IPT sensor error
The input detects a resistance value (ohm) outside the expected range or a short circuit.
- ▶ E3 OT sensor error
The input detects a resistance value (ohm) outside the expected range or a short circuit.
- ▶ E4 OPT sensor error
The input detects a resistance value (ohm) outside the expected range or a short circuit.
- ▶ E5 Infan fan error
Internal electric fan speed is out of the allowable range.
- ▶ E6 Outfan fan error
External electric fan speed is out of the allowable range.
- ▶ E7 Driver communication
- ▶ E8 Communication error between display and MCU
- ▶ Communication error between wall control panel and electronic board
- ▶ OF Float error
High-level float switch triggered in the condensate collection tray.
- ▶ CP Presence contact error
The unit only operates with the CP contact closed.
- ▶ Alr Compressor discharge sensor error

8. START-UP

8.1 First start-up

Preliminary Checks

Before commissioning, check that:

Operational checks

- all safety conditions have been met
- the unit has been properly secured to the supporting surface or wall
- the minimum technical spaces have been observed

Airflows

- the airflow connections have been made according to the instructions in the manual
- all airflow connections are correctly secured
- the ducting is correctly supported
- the ducting does not have any bottlenecks
- the ducting is thermally insulated

Electrical checks

- the cross-section of the power supply cables is adequate for the absorption of the appliance and the length of the connection made
- grounding is correctly performed
- the electrical connections have been established correctly
- all control wires are connected and that all electrical connections are secure

Settings









Airflow setting

It is essential to set the pressure on the fans correctly to ensure the proper airflow.

This operation is essential because a refrigeration circuit with a heat pump may not function properly if it does not receive the correct airflow, compromising the delivery of the desired power.

It is possible to set programs with three predefined pressure settings, useful for the indoor and outdoor sides, by selecting one of the eight available combinations.



To select a program from the M7 control panel

- ▶ from the control panel when off, hold down the  button until  appears
- ▶ use the  and  buttons to select 
- ▶ Press  to change settings
- ▶ use the  and  buttons to select the desired program
- ▶ Press  to confirm

Program	Description	Indoor Side	Useful Pressure (Pa) and (Inch water)	Outdoor Side	Useful Pressure (Pa) and (Inch water)
P1	IN LOW / OUT LOW	LOW	25	LOW	25
P2	IN MED / OUT LOW	MED	75	LOW	25
P3	IN HIGH / OUT LOW	HIGH	120	LOW	25
P4	IN LOW / OUT MED	LOW	25	MED	75
P5	IN MED / OUT MED	MED	75	MED	75
P6	IN HIGH / OUT MED	HIGH	120	MED	75
P7	IN LOW / OUT HIGH	LOW	25	HIGH	120
P8	IN HIGH / OUT HIGH	HIGH	120	HIGH	120

Air flow setting from onboard panel

To select a program from the onboard panel

- ▶ with control panel off, press and hold the  button until P1 appears
- ▶ press  to change mode from P1 to P8
- ▶ Press  to confirm

Program	Description	Indoor Side	Useful Pressure (Pa) and (Inch water)	Outdoor Side	Useful Pressure (Pa) and (Inch water)
P1	IN LOW / OUT LOW	LOW	25	LOW	25
P2	IN MED / OUT LOW	MED	75	LOW	25
P3	IN HIGH / OUT LOW	HIGH	120	LOW	25
P4	IN LOW / OUT MED	LOW	25	MED	75
P5	IN MED / OUT MED	MED	75	MED	75
P6	IN HIGH / OUT MED	HIGH	120	MED	75
P7	IN LOW / OUT HIGH	LOW	25	HIGH	120
P8	IN HIGH / OUT HIGH	HIGH	120	HIGH	120

Start-up

After all checks have been carried out, the unit can be put into operation.

To activate the appliance:

- ▶ please refer to the user manual

Independent control of the VMC side

The fan adjustment is carried out using the trimmer located inside the electrical panel. To set the desired airflow rate, it is necessary to turn the corresponding knob.

⚠ For each fan, two auxiliary functions are available: ON/OFF and booster, see chapter "[Ref]" .

Checks with the machine switched on

After starting up, check that

Operational checks:

- verify the different modes of operation
- verify that the appliance stops and then restarts
- switch the appliance off and on again and check that it restarts correctly
- the appliance operates within the recommended operating conditions (see technical specifications table)
- check that the air flow rates are correct

Hydraulic Checks

- check for proper condensate drainage

Electrical Checks

- the current absorbed is less than the maximum indicated in the technical data table
- the supply voltage value is within the set limits and does not fall below the nominal value -10 % during operation

8.2 Plant delivery

Once all the checks and controls on the correct operation of the plant have been completed, the installer must explain the following to the user:

- the basic functional characteristics of the appliance
- the instructions for use
- the routine maintenance

8.3 Switching off for extended periods

If the appliance is not used for a long period of time, the following steps must be taken:

- ▶ deactivating the device
- ▶ isolate the power supply
- ⚠** To restart the appliance after it has been out of use for a long period, call in the Authorised Service Centre.

9. MAINTENANCE

9.1 Routine maintenance

Annual operations

The once-a-year maintenance plan includes the following operations and checks and must be carried out by the Authorised Service Centre or by qualified personnel.

Electrical circuit

Check:

- electrical supply voltage
- the electrical absorption
- tightening connections
- that there is no damage or excessive wear to electrical cables
- that the gaskets and sealing materials have not deteriorated to such an extent that they are no longer suitable for the purpose of preventing the development of flammable atmospheres inside
- the correct fixing of cable glands
- safety devices

Mechanical checks

Check:

- tightening of the screws, fans and electrical box, of the unit's external panelling
- the state of the structure
- ⚠ Bad fixings result in abnormal noise and vibration.
- ⚠ If oxidised parts are present, treat them with suitable paints to eliminate or reduce oxidation.

Hydraulic controls

Check:

- the regular drainage of condensate
- cleaning the condensate collection trays
- cleaning the exhaust ducts

Airflow controls

Check:

- the regular flow of air
- cleaning of any intake grilles
- cleaning the ducting

Cleaning

- cleaning of aesthetic cover
- cleaning or filter replacement
- cleaning the heat exchanger

Cleaning or filter replacement

1. Filter

2. Filter access hatch

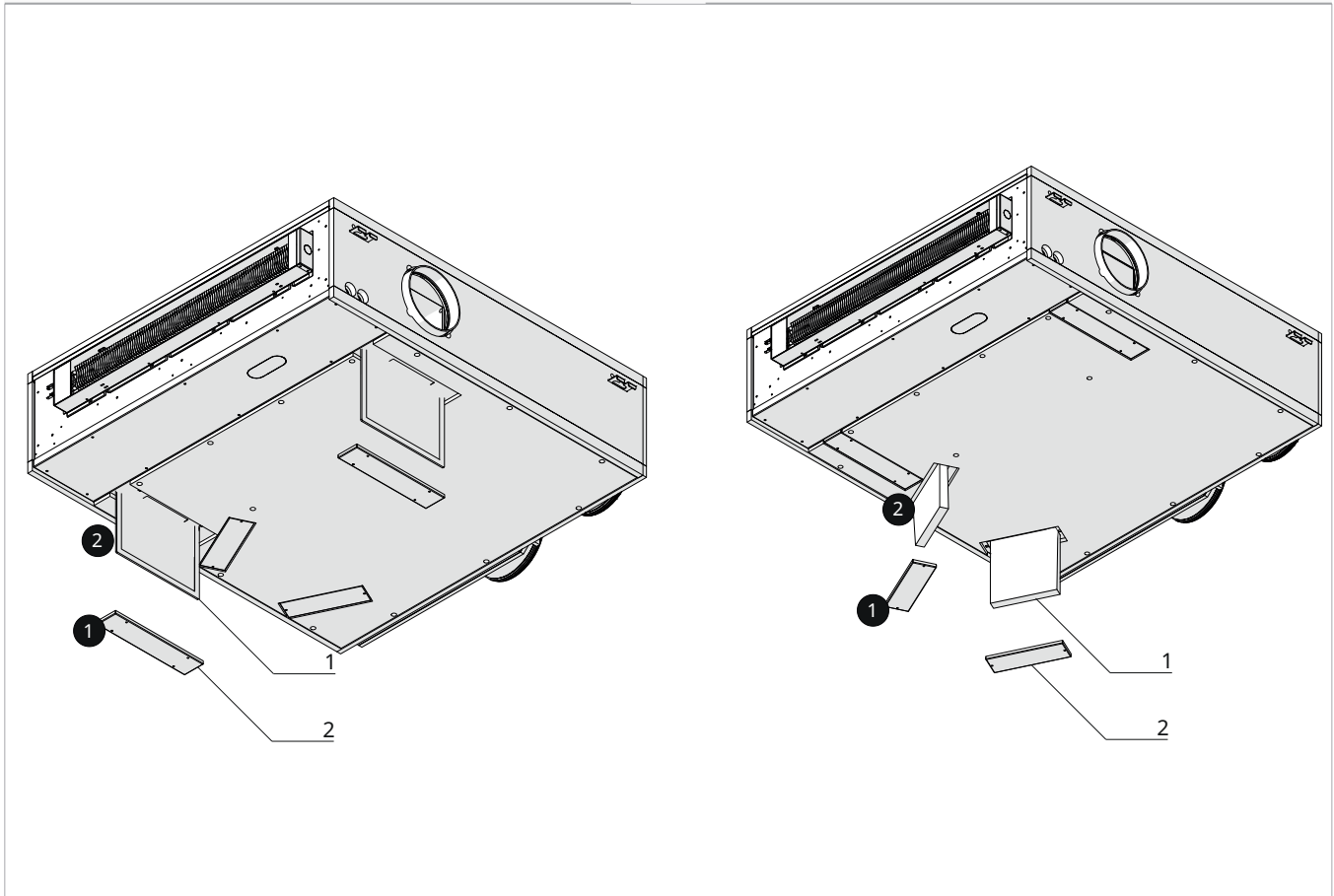

To remove:

- ▶ isolate the power supply to the unit
- ▶ remove the filter access hatch
- ▶ take out the filter

⚠ Pay attention to sharp surfaces

- ① **If the condition of the filters is acceptable, they can be cleaned using a vacuum cleaner or a low-pressure compressor.**
- ① **If it is impossible to clean them, the filters must be replaced.**

To reposition:

- ▶ perform in reverse order
- ⚠ Clean the filters every 3 months to maintain the unit's efficiency and ensure correct operation over time

Cleaning the heat exchanger

Cleaning the heat exchanger

1. Lower panel
2. insulating panel

3. Condensate collection tray for HPU

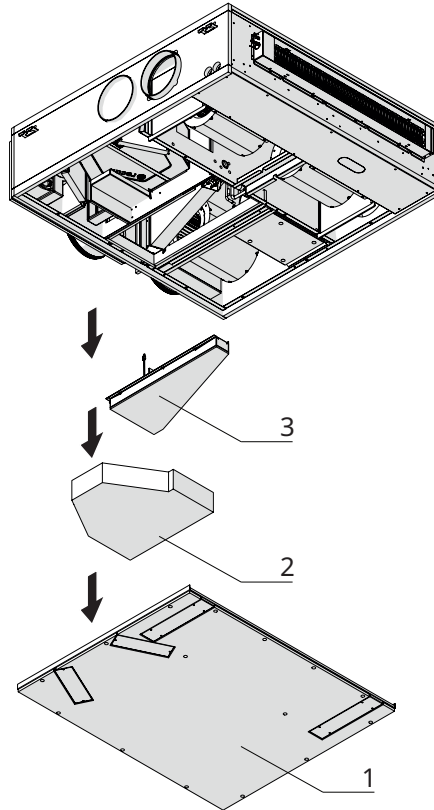

1. Heat exchanger
2. VMC condensate collection tray

3. Holes for tray removal

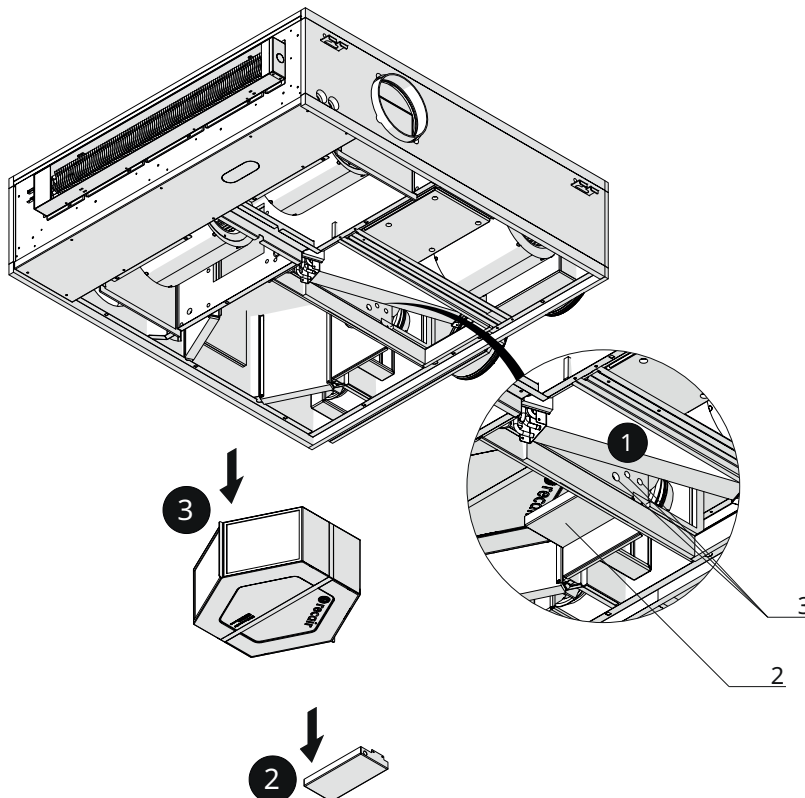

- ▶ isolate the power supply to the unit
- ▶ disconnect the condensate drain pipe
- ▶ remove the lower panel of the unit by releasing the fixing hooks and removing the screws
- ▶ remove the insulation panel
- ▶ remove the PDC condensate collection tray
- ▶ remove the screws from the condensate collection tray
- ▶ remove the VMC condensate collection tray
- ▶ extract the heat exchanger
- ▶ gently proceed with cleaning using a vacuum cleaner or a low-pressure compressor

To reposition:

- ▶ perform in reverse order
- ⚠ Never touch the fins of the heat exchanger, handle only the closed sides.
- ⓘ **There is a special clamp/green strap for removing the heat exchanger.**
- ⓘ **To prevent dirt from entering the heat exchanger, clean in the opposite direction to the air flow.**

10. FAULTS AND REMEDIES

10.1 Preliminary warnings

⚠ For safety warnings, requirements, checks and procedures related to the refrigerant, refer to the section "Information related to the refrigerant".

If one of the following faults is found:

- ventilation does not activate
- the appliance makes excessive noise
- there is dew formation on the front panel

Follow the instructions below:

- ▶ immediately isolate the power supply
- ▶ contact an Authorised Service Centre or professionally qualified personnel
- ⚠ The intervention must be carried out by a qualified installer or an Authorised Service Centre.
- ⊘ Personal intervention is prohibited.

10.2 Troubleshooting table

DESCRIPTION OF FAULT	CAUSE	REMEDY
Display off	No power supply (light switch off)	Check the electrical connection to the power supply
Low or absent air flow, the rooms remain humid	Clogged filters	Replace filters
	Clogged heat exchanger	Clean the heat exchanger
	Frozen heat exchanger	Move the heat exchanger to a warm place and wait for it to defrost. Do not heat it directly with heat sources
	Dirty fan	Clean the fan
	Clogged fan ducts	Clean the ventilation ducts
	Outdoor temperature below 0°C	The unit may be in anti-freeze mode. Wait until the outside temperature increases or consider installing a pre-heating electric heater
High noise level	Noise coming from the unit	Check for the presence of gaps and/or air leaks from the unit's panels Check the siphon connection Check if the motors are running correctly (bearings)
	Noise coming from the ducts	Check for the presence of cracks on the intake/exhaust ducts
High vibrations	Vibrating panels	Check the integrity of the panels and aluminum profiles of the unit
		Check the proper closure of the unit's cover and the panel covering the electronic board
		Check that there are no walls that could transmit vibrations to the wall/floor/ceiling
	Imbalanced fan blades	Check the integrity of the fan blades Clean the fans Check that the small metal clips for balancing the fan blades are still present on the fans
Condensate leak	Clogged condensate drain	Clean condensate drain
	The condensation does not flow from the drainage pipe into the collection tray	Check that the unit is perfectly level Check that the condensate drain connections are not clogged
The appliance does not turn on	No power supply	Check if there is power supply voltage Check that the exclusive magneto-thermal switch protecting the appliance has not tripped (if so, reset it). If the issue recurs immediately, contact the Technical Support Service and do not attempt to operate the appliance.
The appliance does not cool/heat sufficiently	The set temperature is too high or too low	Check and adjust the temperature setting if necessary
	The air filter is clogged	Check the air filter and clean it if necessary
	Check for any obstructions to the airflow inside or outside	Remove anything that could obstruct the airflow

11. TECHNICAL INFORMATION

11.1 Technical data

		HRA-i PLUS H	
Models		u.m.	50/15-Post heating
VMC airflow performance			
Nominal air flow for supply		m ³ /h	450
Nominal air flow for ventilation		m ³ /h	100
Nominal air flow recirculation		m ³ /h	350
Available pressure		Pa	100
Heating performance (A -5; A 20) (1)			
Total power	(2)	kW	2,58
Net power output excluding ventilation load		kW	2,11
Power delivered in static recovery		kW	0,38
Power delivered in thermodynamic recovery	(3)	kW	2,20
Power absorbed in thermodynamic recovery		kW	0,77
COP			2,86
Cooling performance (A 35; A 27) (4)			
Total power	(2)	kW	2,32
Net power output excluding ventilation load		kW	1,55
Power delivered in static recovery		kW	0,22
Power delivered in thermodynamic recovery	(3)	kW	2,10
Power absorbed in thermodynamic recovery		kW	0,73
EER			2,88
Heat recovery performance (A -5; A 20) (1)			
Sensible recovery efficiency		%	81
Enthalpy recovery efficiency		%	53
Electric post-heating			
Electric heater power		kW	1,8
Heat exchanger			
Type			Cross-flow polypropylene in countercurrent
Number		No.	1
Supply fan			
Type			Forward-curved centrifugal fans with double EC brushless suction
Number		No.	2
Maximum absorbed power		W	190
Outdoor side fan			
Type			Forward-curved centrifugal fans with double EC brushless suction
1. Outdoor air temperature -5 °C / 80 % RH; indoor air temperature 20 °C / 50 % RH 2. The total power refers to the power delivered in thermodynamic recovery plus the power recovered through the heat exchanger 3. Power delivered to the indoor air in recirculation only 4. Outdoor air temperature 35 °C / 50 RH; indoor air temperature 27 °C / 60 % RH 5. Data refers to the UNI EN 3741 and UNI EN 3744 standards			

Models		u.m.	HRA-i PLUS H
			50/15-Post heating
Number		No.	1
Maximum absorbed power		W	150
VMC Stale air exhaust fan			
Type			Backward curved EC brushless centrifugal fans
Number		No.	1
Maximum absorbed power		W	60
VMC Fresh air inlet fan			
Type			Backward curved EC brushless centrifugal fans
Number		No.	1
Maximum absorbed power		W	60
HRV fresh air filter			
Type			Pleated flat filter
Number		No.	1
Efficiency			ePM1 80%
VMC Extract air filter			
Type			Pleated flat filter
Number		No.	1
Efficiency			ePM1 80%
Air recirculation filter			
Type			Nylon flat filter
Number		No.	2
Efficiency			Coarse ePM10 30%
Compressor			
Type			Rotary BLDC
Number		No.	1
Refrigerant type			R32
Refrigerant quantity		kg	0,48
Maximum absorbed power		W	1.400
Electrical characteristics			
Power supply		V / ph / Hz	230 / 1 / 50
Maximum total absorbed power		W	3.703
Maximum total absorbed current		A	16,10
Protection rating		IP	20
Room side sound levels (UNI EN 3741; 3744) (5)			
Sound power transmitted to the Lw structure		dB (A)	63,0
Sound power radiated in the Lw channel		dB (A)	65,0
Average sound pressure at 1 m Lp		dB(A)	49,0
Average sound pressure at 3 m Lp		dB(A)	41,0
Product dimensions			
Width		mm	1.052
<ol style="list-style-type: none"> 1. Outdoor air temperature -5 °C / 80 % RH; indoor air temperature 20 °C / 50 % RH 2. The total power refers to the power delivered in thermodynamic recovery plus the power recovered through the heat exchanger 3. Power delivered to the indoor air in recirculation only 4. Outdoor air temperature 35 °C / 50 RH; indoor air temperature 27 °C / 60 % RH 5. Data refers to the UNI EN 3741 and UNI EN 3744 standards 			

		HRA-i PLUS H	
Models		u.m.	50/15-Post heating
Length		mm	1.134
Height		mm	279
Weight		kg	81,1
1. Outdoor air temperature -5 °C / 80 % RH; indoor air temperature 20 °C / 50 % RH 2. The total power refers to the power delivered in thermodynamic recovery plus the power recovered through the heat exchanger 3. Power delivered to the indoor air in recirculation only 4. Outdoor air temperature 35 °C / 50 RH; indoor air temperature 27 °C / 60 % RH 5. Data refers to the UNI EN 3741 and UNI EN 3744 standards			

11.2 Dimensions

Unit with post heating

A	Display
B	Filter port
C	Male aeraulic connection Ø 160
D	Male aeraulic connection Ø 200

E	Installation bracket
F	Power supply
G	Condensate drain Ø 18

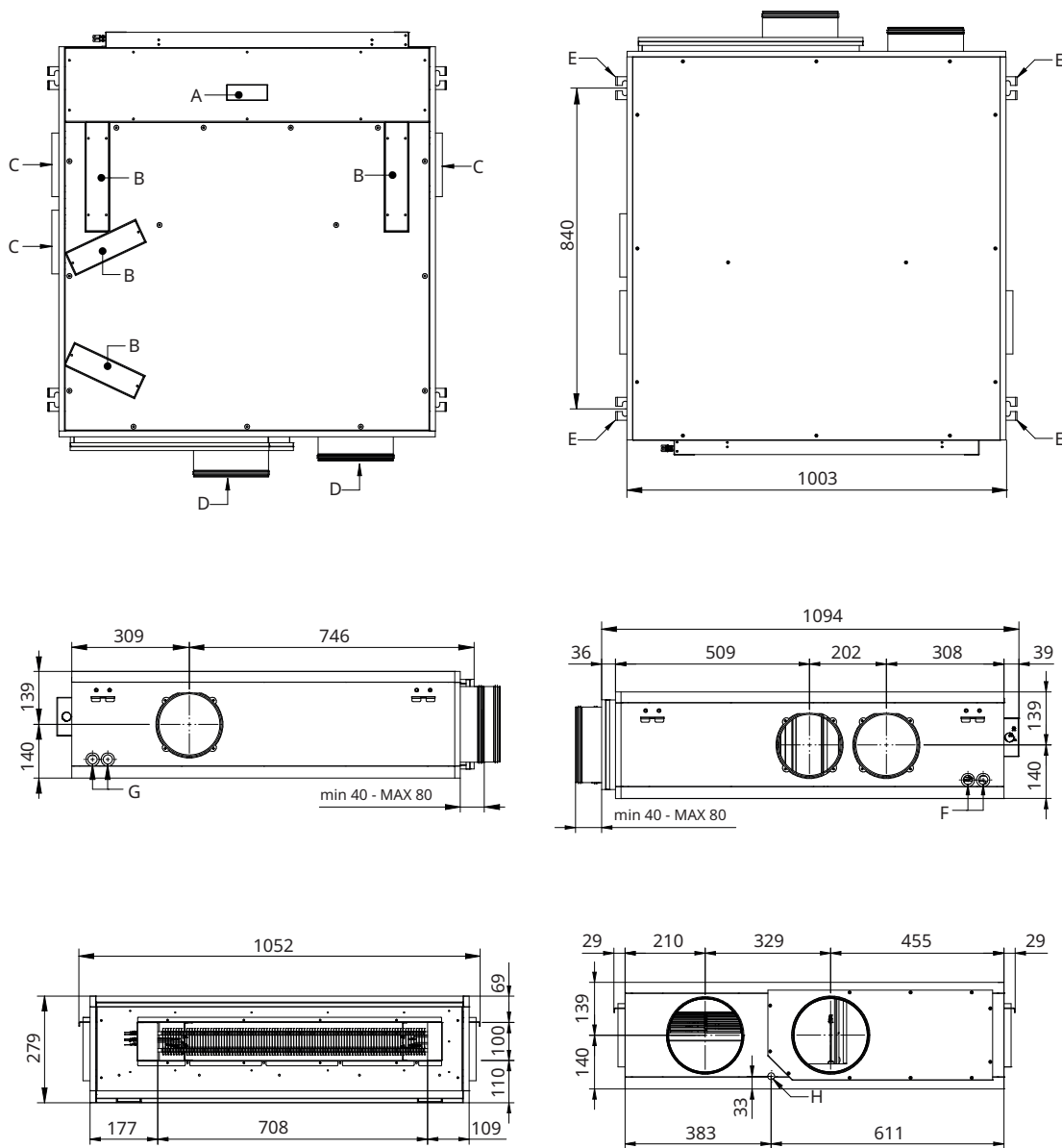



innova

INNOVA S.r.l.
Via I Maggio 8 - 38089 (TN) - ITALY
tel. +39.0465.670104 - fax +39.0465.674965
info@innovaenergie.com