

Installation manual
(Translation of original language)

EN



innova

- Rev.00 - 05/2024

**Decentralized heat recovery
unit**

First of all, we would like to thank you for having chosen one of our units.

As you will realise, you have made a winning choice by purchasing a product that represents the state of the art in domestic air-conditioning technology.

Thanks to the product you have purchased and by following the suggestions in this manual, you will benefit from optimal environmental conditions with the lowest possible energy investment.

Compliance

This unit complies with European directives:

- Low Voltage Directive 2014/35/EU by transposition of the following technical standards: EN 60335-1:2012 + EN 60335-2-80:2003
- EMC Directive 2014/30/EU, by transposition of technical standards: EN 55014-1:2021 + EN 55014-2:2021
- + EN IEC 61000-3-2:2019+A1:2021 + EN 61000-3-3:2013+A2:2021
- RoHS Directive 2011/65/EU by transposition of the following technical standards: EN IEC 63000:2018
- European ErP Ecodesign Regulation No. 1254/2014

Markings



CONTENTS

Compliance.	2
Markings	2

1. General information 4

1.1 About the manual	4
1.2 General Warnings	5
1.3 Basic safety rules.	5
1.4 Disposal.	6

2. Product introduction 7

2.1 Identification	7
2.2 Destination of use	7
2.3 Description of the appliance	7
2.4 List of external components	8
2.5 List of internal components.	8
2.6 Compatible accessories.	9

3. Installation 11

3.1 Preliminary Warnings	11
3.2 Reception.	11
3.3 Storage	11
3.4 Installation site.	11
3.5 Minimum installation distances.	12
3.6 Positioning	12
3.7 Electrical connections	16
3.8 Finish	18

4. Remote control 19

4.1 Interface	19
-------------------------	----

5. Start-up. 20

5.1 Preliminary Warnings	20
5.2 First start-up	20
5.3 Plant delivery.	22
5.4 Switching off for extended periods	22

6. Maintenance. 23

6.1 Routine maintenance	23
-----------------------------------	----

7. Faults and remedies. 25

7.1 Preliminary Warnings	25
7.2 Troubleshooting Table.	25

8. Technical information 26

8.1 Technical data	26
8.2 Dimensions.	27

1. GENERAL INFORMATION

1.1 About the manual

This manual was written to provide all the explanations for the correct management of the appliance.

- ⚠ This instruction manual is an integral part of the appliance and must therefore be kept in a safe place and must ALWAYS accompany the appliance even if it is passed on to another owner or user, or transferred to another plant. If it is damaged or lost, download a copy from the website.
- ⚠ Read this manual carefully before proceeding with any operation and follow the instructions in the individual chapters.
- ⚠ Specific warnings are given in each chapter of the document and should be read before starting operations.
- ⚠ The manufacturer accepts no liability for damage to persons or property resulting from failure to observe the regulations contained in this booklet.
- ⚠ This document is confidential under the terms of the law and may not be reproduced or passed on to third parties without the express authorisation of the company.

Editorial pictograms

The pictograms in the following chapter provide quick and unambiguous information necessary for the correct and safe use of the machine.

Related to safety

⚠ High risk warning (bold text)

- The operation described above presents a risk of serious physical injury, fatality, major damage to the appliance and/or to the environment if not carried out in compliance with safety regulations.

⚠ Low risk warning (plain text)

- The operation described above presents a risk of minor physical injury or minor damage to the appliance and/or to the environment if not carried out in compliance with safety regulations.

🚫 Prohibition (normal text)

- Marks actions that absolutely must not be done.

📌 Important information (bold text)

- This indicates important information that must be taken into account during the operations.

In the texts

Purpose of the actions

- ▶ Actions required
Expected responses following an action

- Lists

In the figures

- 1 The numbers indicate the individual components.

A Capital letters indicate a combination of components and dimensions.

- ① The white numbers in black marks indicate a series of actions to be carried out in sequence.
- Ⓐ The black letter in white identifies an image when there are several images in the same figure.

Pictograms on the product

Symbols are used in some parts of the appliance:

Related to safety



Read the instruction manual

Read the instructions carefully before performing any operation on the appliance.



Instruction manual

Read the information available in the technical documentation of the appliance.



Attention electrical hazard

- Warns relevant personnel of the presence of electricity and the risk of electric shock.

Recipients

User

Non-expert person capable of operating the product in safe conditions for people, for the product itself and the environment, interpreting an elementary diagnostic of faults and abnormal operating conditions, carrying out simple adjustment, checking and maintenance operations.

Installer

Expert person qualified to position and connect (hydraulically, electrically, etc.) the unit to the plant; this person is responsible for handling and correct installation according to the instructions provided in this manual and the national standards currently in force.

Service

Expert and qualified person authorised directly by the manufacturer to carry out all routine and supplementary maintenance operations, as well as every adjustment, check, repair and replacement of parts necessary during the life of the unit itself.

Organisation of the manual

The manual is divided into sections each dedicated to one or more target groups.

General information

It addresses all recipients.

It contains general information and important warnings that should be known before installing and using the appliance.

Product introduction

Addressed to all recipients, contains general information on the product.

Installation and Operation

It is addressed exclusively to the installer.

Contains specific warnings and all information necessary for positioning, mounting, connecting the device and operation.

Commissioning, maintenance and troubleshooting

They are addressed exclusively to the Technical Assistance Centre.

It contains specific warnings useful information for the most common commissioning and routine maintenance.

Technical information

It addresses all recipients.

It contains detailed technical information about the appliance.

1.2 General Warnings

- ⚠ Specific warnings are given in each chapter of the document and should be read before starting operations.
 - ⚠ All personnel involved must be aware of the operations and dangers that may arise when beginning all unit installation operations.
 - ⚠ Installation performed outside the warnings provided in this manual and use of the appliance outside the prescribed temperature limits will invalidate the warranty.
 - ⚠ Any contractual or extra-contractual liability for damage caused to persons, animals or property, due to installation, adjustment and maintenance errors or improper use is excluded. All uses not expressly indicated in this manual are not permitted.
 - ⚠ The installation of the appliances must be carried out by a qualified company which, on completion of the work, will issue a declaration of compliance to the person in charge of the plant in accordance with the regulations in force and the instructions provided in the instruction booklet accompanying the appliance.
 - ⚠ First start-up and repair or maintenance operations must be carried out by the Technical Assistance Centre or by qualified personnel following the provisions of this manual.
 - ⚠ Do not modify or tamper with the appliance as this can lead to dangerous situations.
 - ⚠ Use suitable accident-prevention clothing and equipment during installation and/or maintenance operations.
- The manufacturer is not liable for the non-observance of the current safety and accident prevention regulations.
- ⚠ In the event of spillage of liquids, oil, set the system's main switch to "off" and close any water taps. Call the authorised Technical Assistance Centre or professionally qualified personnel as soon as possible and do not work on the appliance yourself.
 - ⚠ When replacing components, use only original spare parts.
 - ⚠ The manufacturer reserves the right to make changes to its models at any time to improve its product, without prejudice to the essential characteristics described in this manual. The manufacturer is not obliged to add such modifications to machines previously manufactured, already delivered or under construction.
 - ⚠ The appliance can be used by children aged 8 years and above and by persons with reduced physical, sensory, or mental capabilities, or those lacking experience or necessary knowledge, provided they are under supervision or have been given instructions concerning the safe use of the appliance and understand the hazards involved. Children should not play with the appliance. Cleaning and maintenance intended to be carried out by the user should not be done by children without supervision.

1.3 Basic safety rules

We would like to remind you that the use of products that use electricity and water involves observing certain basic safety precautions such as:

- ⊖ It is forbidden to touch the appliance with wet or damp body parts.
- ⊖ It is forbidden to carry out any operation before disconnecting the appliance from the power supply by setting the plant master switch to "off".
- ⊖ It is forbidden to modify the safety or adjustment devices without the authorisation and instructions of the appliance manufacturer.
- ⊖ It is forbidden to pull, unplug or twist the electrical cables coming out of the appliance, even if it is disconnected from the mains supply.
- ⊖ It is forbidden to introduce objects and substances through the openings provided for the intake and delivery of air.
- ⊖ It is forbidden to open the access doors to the internal parts of the appliance without first setting the plant master switch to "off".
- ⊖ It is forbidden to dispose of packaging material and leave it within reach of children as it can be a potential source of danger.

1.4 Disposal

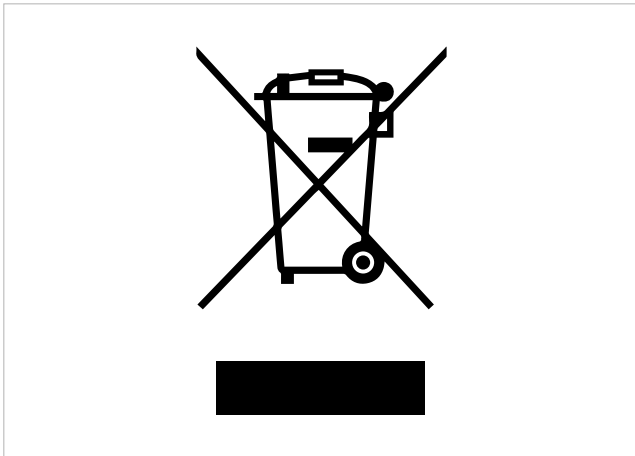

The symbol on the product or packaging indicates that the product should not be treated as normal household waste. Instead, it should be taken to an appropriate collection point for recycling of electrical, electronic, and battery equipment.

Proper disposal of this product avoids harm to humans and the environment and promotes the reuse of valuable raw materials.

For more detailed information about the recycling of this product, contact your local city office, your household waste disposal service or the shop where you purchased the product.

Illegal disposal of the product by the user involves the application of the administrative sanctions provided for by the regulations in force.

This provision is only valid in the EU Member States.

⚠ Avoid disassembling the appliance yourself.

⚠ **Contact an authorised Technical Assistance Centre to disassemble the appliance.**

2. PRODUCT INTRODUCTION

2.1 Identification

The appliance can be identified by the rating plate:

1. Technical rating plate

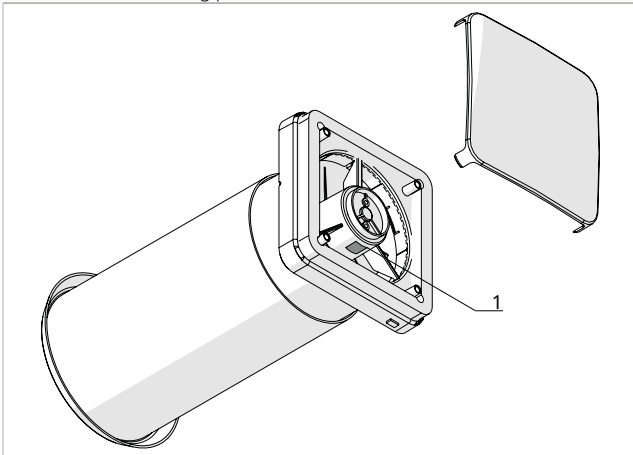

Technical rating plate

This shows the technical and performance specifications of the appliance.

⚠ Tampering with, removing or missing identification plates does not allow the product to be reliably identified by its serial number and therefore invalidates the warranty.

2.2 Destination of use

The unit is a heat recovery device that allows high-performance Controlled Mechanical Ventilation without the need for a system with ducts, diffusers, and centralized units. The device operates on the principle of regenerative heat recovery through a ceramic heat exchanger inside the unit and a DC Brushless fan with reverse cycle operation.

The air is constantly filtered through a Coarse filter installed on the front plate and is easily accessible. The control systems allow the choice of autonomous or coordinated operation of the installed units via a temperature, humidity, light, and IAQ sensor.

2.3 Description of the appliance

Structure: high-resistance structure made of anti-UV and antistatic ABS

Fans: the unit is equipped with axial fans with DC Brushless motor

Heat exchanger: high-efficiency regenerative heat exchanger

Filtration: low-pressure drop G3 filter

Installation kit: telescopic pipe installation kit and external grille with flexible net for installation from inside and outside

Control: system management entrusted to advanced but easy-to-use electronics; it manages automatic, manual, and combined operation

Models: 2 sizes available with different capacities

2.4 List of external components

Configuration A

- 1. Telescopic air duct
- 2. LED
- 3. Aesthetic cover

- 4. Filter
- 5. Grille

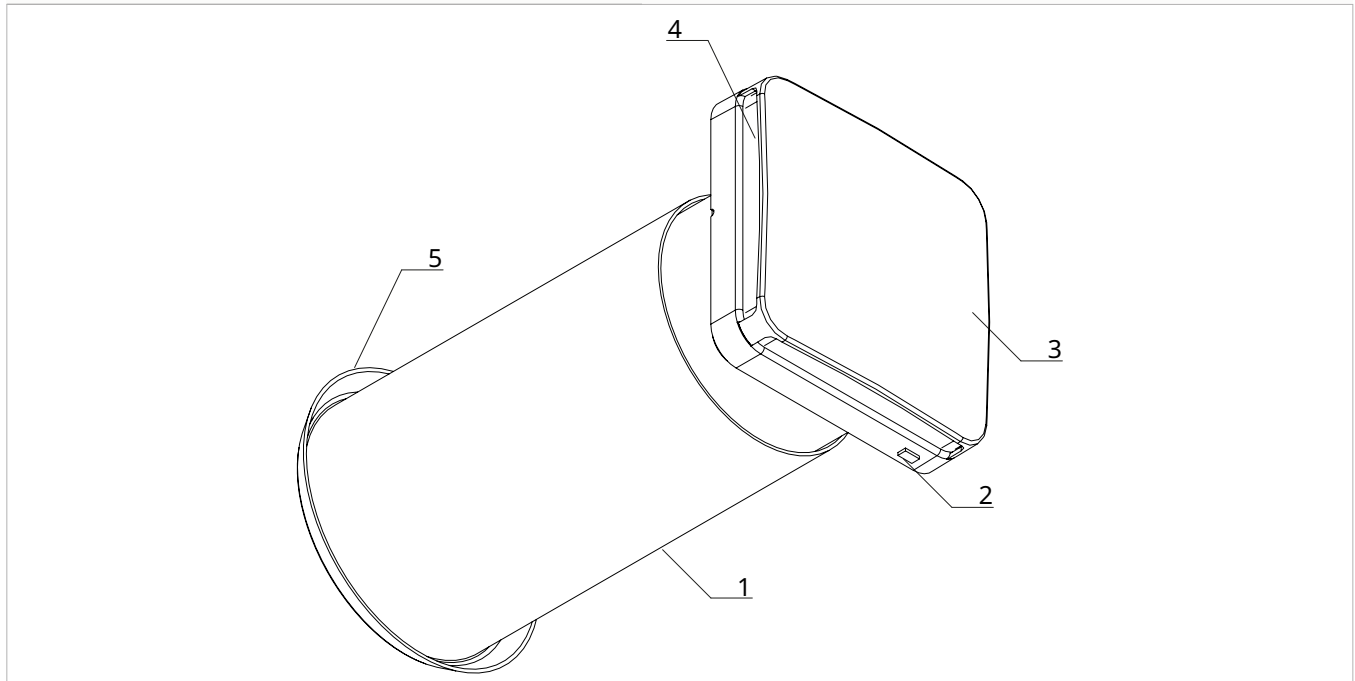

2.5 List of internal components



Configuration A

- 1. Ceramic heat exchanger
- 2. Fan cover
- 3. Pre-cut for external electrical connection

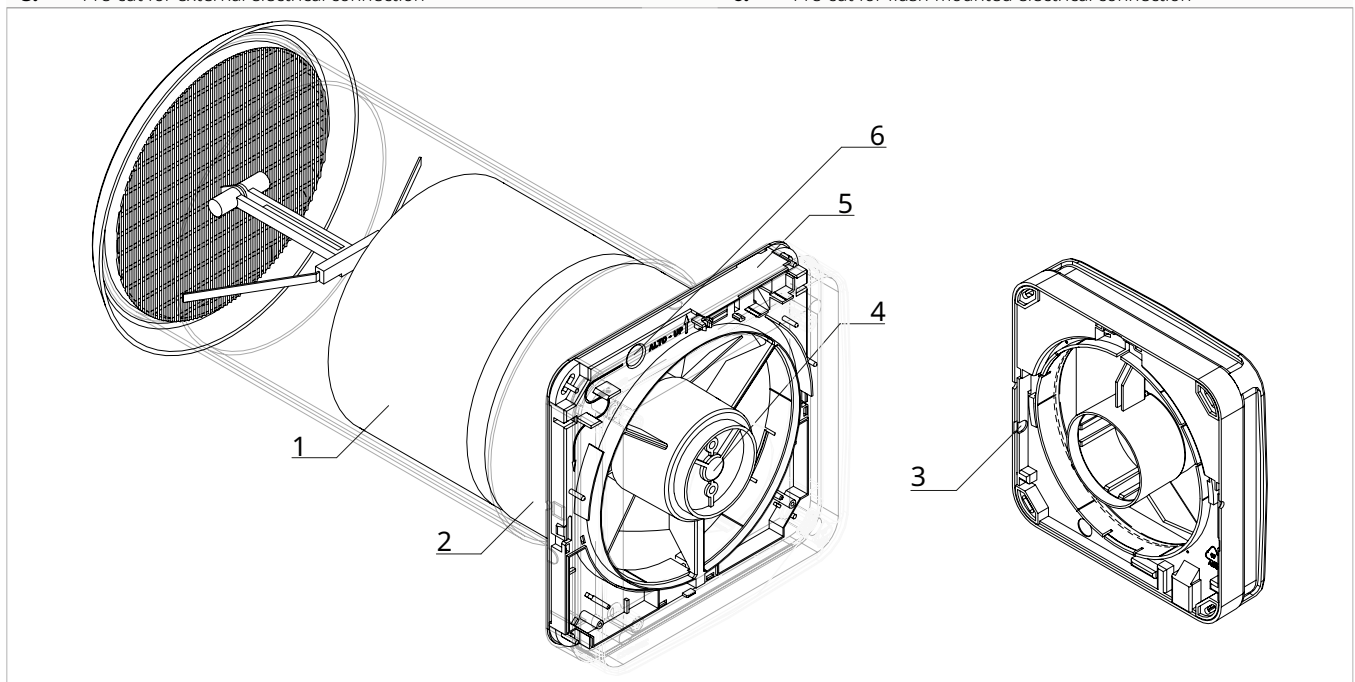
- 4. Fan
- 5. Device body
- 6. Pre-cut for flush-mounted electrical connection

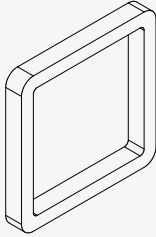
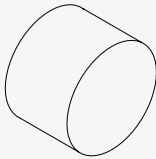
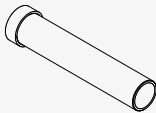

2.6 Compatible accessories

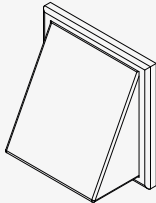
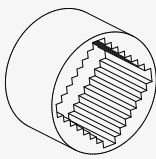
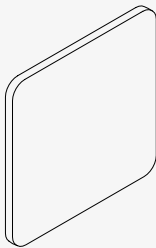
Description		Code
Standard filter		
	FDR - Replacement G3 filter	AHRC0041II
Replacement ceramic heat exchanger		
	SCR1 - Replacement ceramic heat exchanger Dn 100	AHRC0052II
	SCR2 - Replacement ceramic heat exchanger Dn 160	AHRC0051II
ISO kit + ISO predisposition		
	KIS1 - Predisposition hole with insulated pipe Dn 100	SCE112001II
	KIS2 - Predisposition hole with insulated pipe Dn 160	SCE116001II
Angle kit		
	KUA1 - Angle exit kit Dn 100	AHRC0090II
	KUA2 - Angle exit kit Dn 160	AHRC0091II
External ABS grilles		
	Aesthetic plastic external grille Dn 100	AHRC0030II
	Aesthetic plastic external grille Dn 160	AHRC0031II
Silencers		
	Silencer for unit Dn 100	AHRC0032II
	Silencer for unit Dn 160	AHRC0033II
Aesthetic covers		
	CF1 - Metal mirror front cover	AHRC0111II
	CF2 - Satin metal front cover	AHRC0112II
	CF3 - Corten metal front cover	AHRC0113II
	CF4 - Glossy metal front cover	AHRC0121II
	CF5 - Glossy black front cover	AHRC0122II
	CF6 - Wenge wood front cover	AHRC0131II
	CF7 - Whitewashed wood front cover	AHRC0132II
	CF8 - Natural wood front cover	AHRC0133II
	CF9 - MDF front cover	AHRC0141II
Accessories		

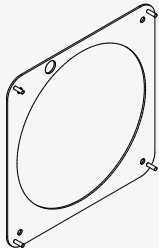
Description	Code
 <p data-bbox="523 331 657 362">Mounting frame</p>	AHRC0061II

3. INSTALLATION

3.1 Preliminary Warnings

- ⚠ **For detailed information on the products, refer to chapter 8 p. 26.**
- ⚠ Installation must be carried out by the installer. If installation is not performed correctly, there may be a risk of electric shock or fire.
- ⚠ During installation, it is necessary to observe the precautions mentioned in this manual, and on the labels affixed to the inside of the appliances, as well as to take

every precaution suggested by common sense and the safety regulations in force at the place of installation.

- ⚠ Using only the supplied installation-specific components is recommended. Use of different components could lead to water leakage, electric shock or fire.
- ⚠ Failure to apply the indicated rules may cause malfunctions of the appliances and relieves the manufacturer from any warranty and from any damage caused to persons, animals or property.

3.2 Reception

Preliminary Warnings

- ⚠ Upon receipt of the package check that it is not damaged, otherwise accept the goods with reserve, producing photographic evidence of any damage.
- ⚠ In the event of damage, notify the shipper by registered mail with return receipt within 3 days of receipt. Presenting photographic documentation, similar information should also be sent by fax to the manufacturer.
- ⚠ No reports of damage will be taken into account later than 3 days after delivery.

Package description

The packaging is made of suitable material and carried out by experienced personnel.

The units are all checked and tested and are delivered complete and in perfect condition.

The appliance is shipped in the standard packaging consisting of a cardboard box and a set of polystyrene foam protectors.

3.3 Storage

Preliminary Warnings

- ⚠ Stored in accordance with the applicable national regulations.

- ⚠ Store in a closed environment protected from the weather, off the ground by means of sleepers or pallets with temperatures not below 0 °C, up to a maximum of 40 °C.

3.4 Installation site

The location of the appliance must be determined by the plant engineer or a competent person and must take into account both purely technical requirements and any national/local legislation in force.

The device is intended to be installed indoors.

- ⚠ The installation position must be chosen close to a wall connected to the outside.
- ⚠ The appliance is declared IPX0 protected, therefore not suitable for installation outdoors or in rooms with the presence of water (swimming pool, etc.).

Preliminary Warnings

- ⚠ Avoid installing the unit in the vicinity of:
 - obstacles or barriers that cause recirculation of the exhaust air

- narrow places where the sound level of the appliance can be enhanced by reverberations or resonances
- environments with the presence of flammable or explosive gases
- very damp environments (laundries, greenhouses, bathrooms with high humidity, etc.) to prevent the formation of condensation on the external panels of the unit
- environments with the presence of flammable or explosive gases or flammable fluids
- solar radiation and proximity to heat sources
- ⚠ **Avoid installing the unit in the vicinity of the sea. Salty atmospheres cause corrosion and oxidation of the internal components, compromising the functioning of the unit.**

- ⚠ Avoid placing the unit within 1 metre of radio and video equipment.
- ⚠ Do not install above heat sources.
- ⚠ Ensure that:
 - the installation site of the unit must be chosen with the utmost care to guarantee adequate protection from shocks and consequent damage
 - the supporting surface is capable of supporting the weight of the appliance
 - the supporting surface does not affect load-bearing building elements, piping or power lines
 - the functionality of load-bearing elements is not compromised

- there are no obstacles to the free circulation of air through the holes (plants, leaves...)
- the appliance must be installed in a position where it can be easily serviced
- the safety distances between the units and other appliances or structures are scrupulously respected so that the air entering and leaving the fans is free to circulate
- ⚠ If the unit is installed incompletely or on an unsuitable surface, it could cause damage to persons or property if it becomes detached.
- ⚠ The appliance must not be in a position where the air flow is aimed directly at a person.
- ⚠ Provide a compliant power supply nearby.

3.5 Minimum installation distances

The clearance zones for the installation and maintenance of the appliance are shown in the figure. Established spaces are necessary to avoid barriers to airflow and allow for normal cleaning and maintenance.

- ⚠ Make sure that there is sufficient space to allow the panels to be removed for routine and supplementary maintenance operations.

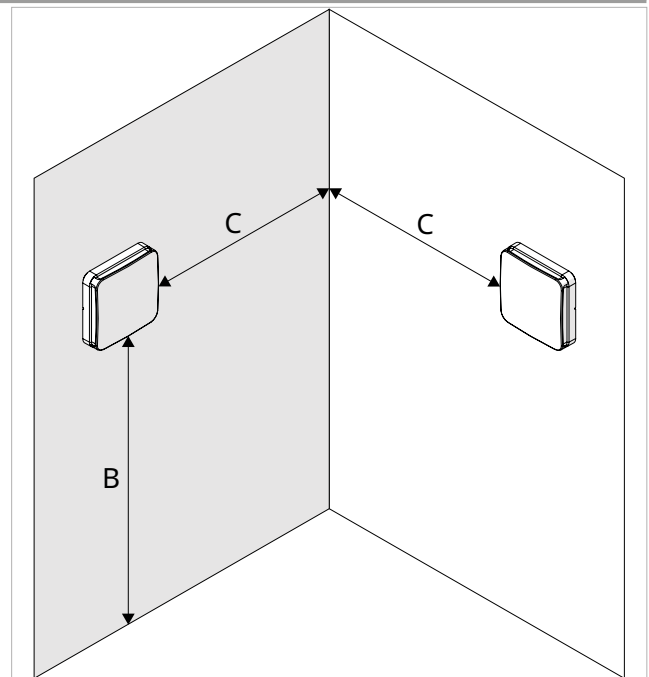
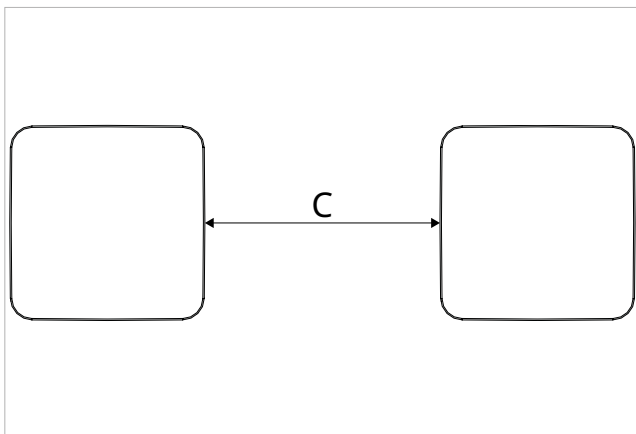
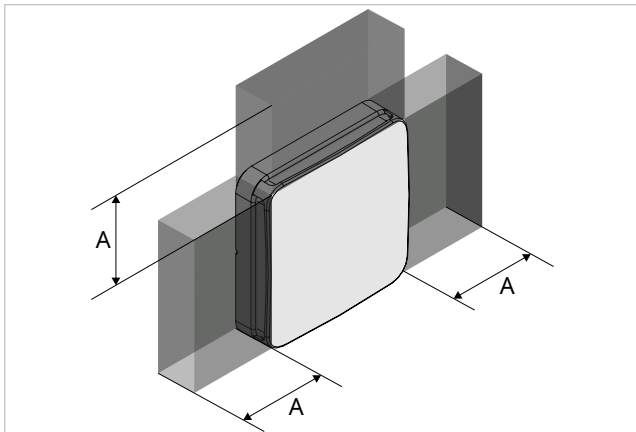

Models	u.m.	02	05
Minimum distances			
A	mm	100	100
B	mm	1800	1800
C	mm	1200	1200

3.6 Positioning

Preliminary Warnings

The unit must be installed indoors.

- ⚠ Check that:
 - the surface does not affect piping or power lines

- the functionality of load-bearing elements is not compromised

Unit installation

General assembly diagram

- | | |
|----|------------------------|
| 1. | Aesthetic cover |
| 2. | Device body |
| 3. | Ceramic heat exchanger |

- | | |
|----|---|
| 4. | Telescopic air duct |
| 5. | Drilling \varnothing 110 model 02, \varnothing 162 model 05 |
| 6. | Grille |

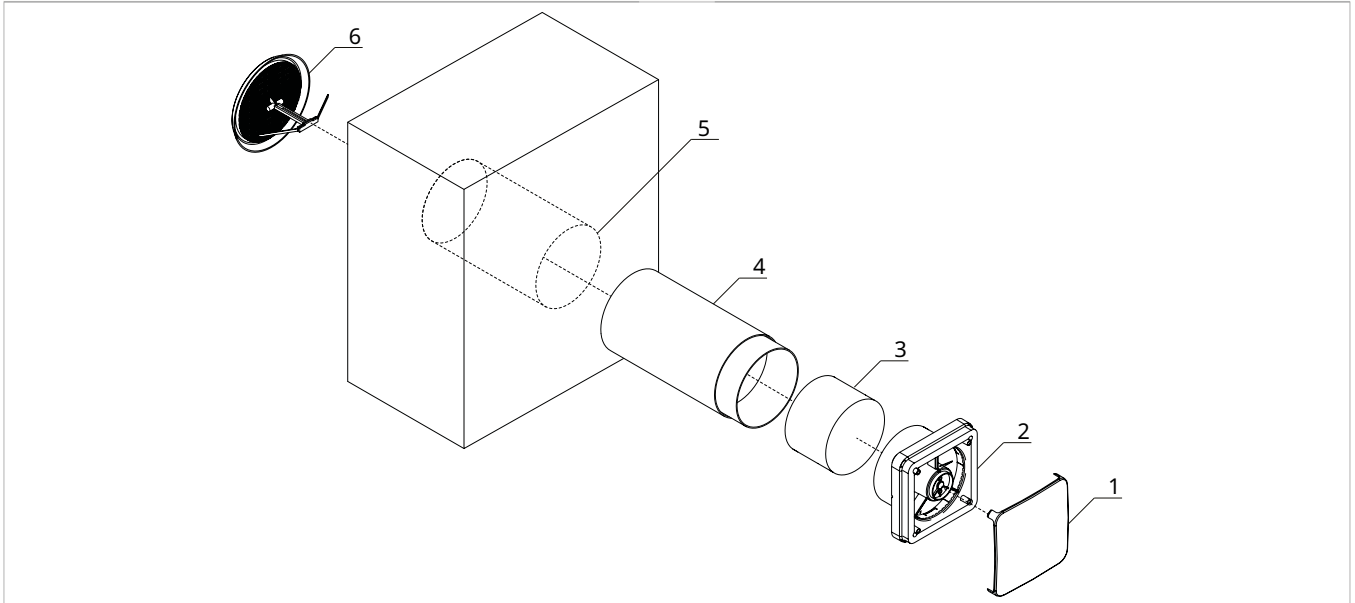

Drilling

- | | |
|---|--------------|
| A | Outdoor side |
| B | Indoor side |

- | | |
|----|---|
| 1. | Drilling \varnothing 110 model 02, \varnothing 162 model 05 |
|----|---|

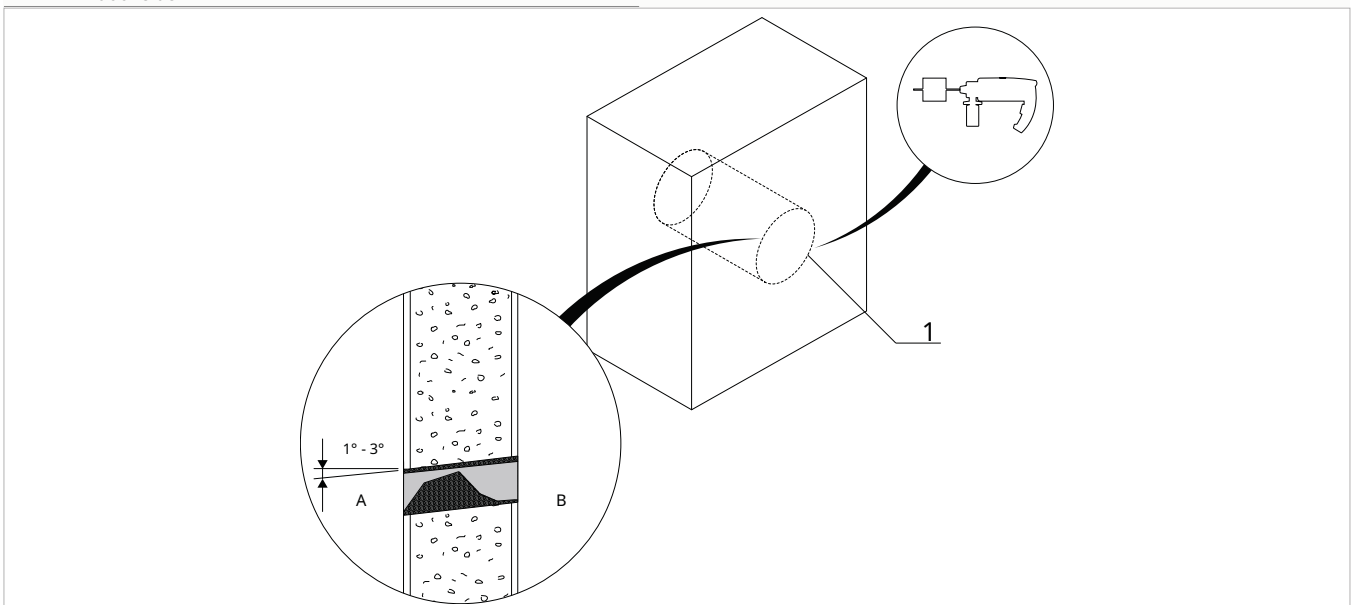

To make the hole:

- ▶ mark the position of the hole
- ▶ use a drill
- ▶ drill a guide hole
- ▶ use a core drill

- ▶ make a hole through the wall
- ▶ maintain a downward slope towards the outside
- ⚠ To avoid the release of large amounts of dust and debris into the room, you are advised to couple the core drill with a vacuum system.
- ⚠ Proceed with caution near the outside wall to avoid breaking the plaster around the hole.

⚠ Take precautions so that the removed material does not hit people and objects below.

Inserting the telescopic air duct

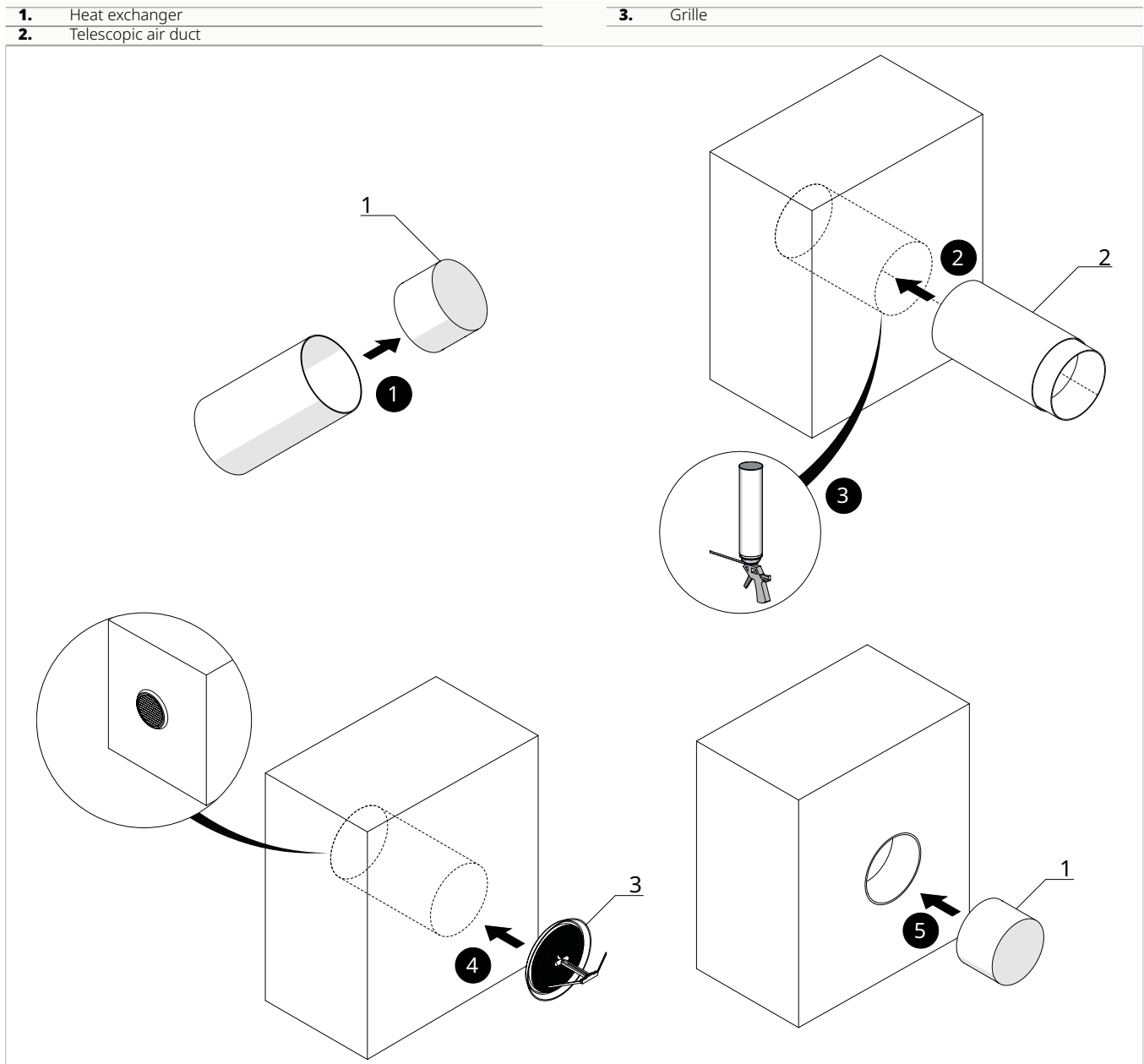

To extract the heat exchanger:

- ▶ use the handle provided on the heat exchanger
- ▶ take out the heat exchanger

To insert the telescopic air duct:

- ⚠ Check that the telescopic air duct is inserted with the smaller diameter tube facing inward.
- ▶ cover the drilled hole with cement mortar or polyurethane foam
- ▶ insert the telescopic duct into the hole
- ▶ align the part of the telescopic duct with the larger diameter with the outer wall surface
- ▶ extract the part of the tube with the smaller diameter
- ▶ align it with the inner wall surface

- ▶ wait for the cement mortar or polyurethane foam to set
- ⚠ If the telescopic air duct is longer than the wall, it must be cut to the required length to ensure proper installation.

To position the external grille:

- ▶ Insert the grille from the inside
- ▶ push the grille until it exits from the outside
- ▶ pull the cord to fit it into the air duct

To reposition the heat exchanger:

- ▶ insert the heat exchanger from the inside towards the end of the tube with the smaller diameter

Mounting the device body

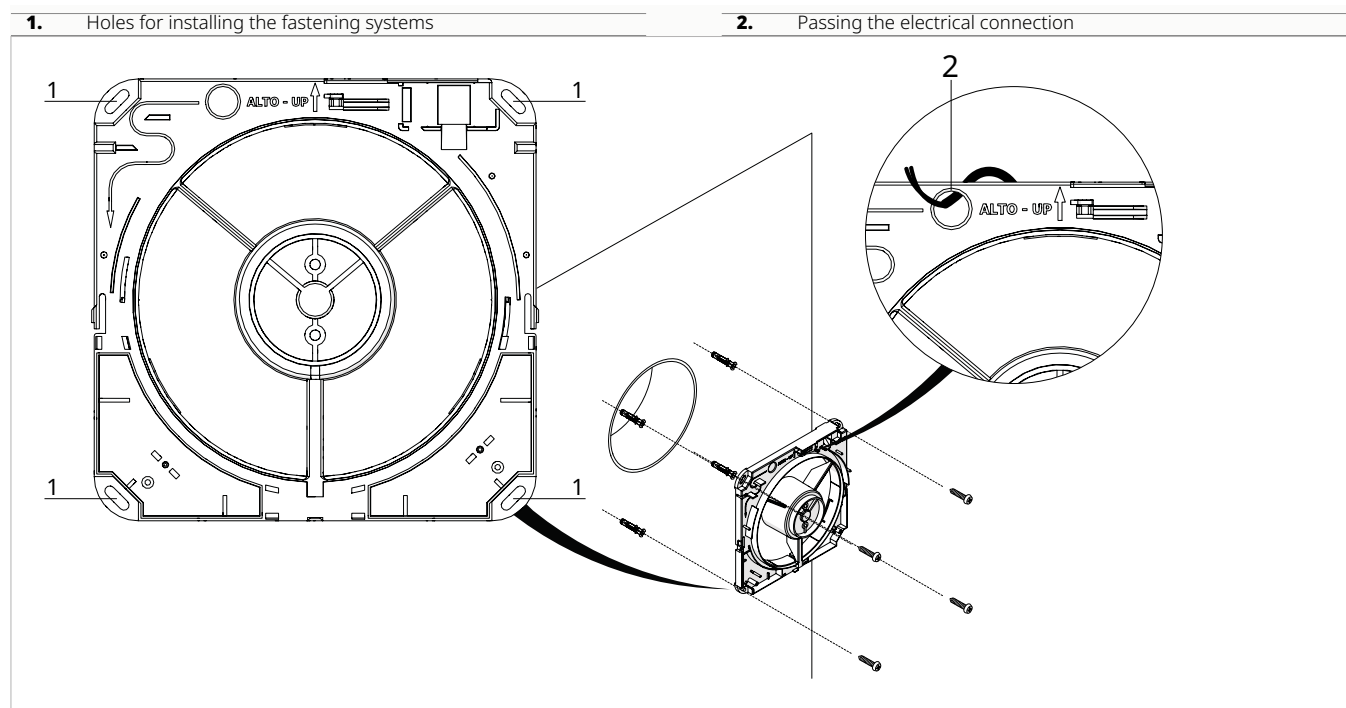

- ⚠ Check the correct orientation of the unit.
- ⚠ If the electrical connection is flush-mounted, the power cable must be prepared before positioning the device body.
- ▶ mark the position of the fixing holes
- ▶ use fixing systems appropriate for the type of supporting surface and the weight of the unit
- ▶ secure the unit to the fixing system
- ⚠ To facilitate assembly, you can use the pre-installation template, available as an accessory.

3.7 Electrical connections

The device leaves the factory fully wired and only requires connection to the power supply.

Preliminary Warnings

- ⚠ All operations of an electrical nature must be carried out by qualified personnel having the necessary legal requirements, trained and informed about the risks related to such operations.
- ⚠ All connections must be made in accordance with the relevant regulations in force in the country of installation.
- ⚠ Before carrying out any work, make sure that the power supply is switched off.
- ⚠ The unit should be powered only after electrical work is completed.
- ⚠ References:
 - for electrical connections please refer to the wiring diagrams in this manual, especially for the part concerning the power terminal board
 -
- ⚠ Check that:
 - the mains characteristics are adequate for the power consumption of the appliance, also taking into account any other machinery in parallel operation
 - the power supply voltage and frequency correspond to those specified on the nameplate on the appliance
 - the cables are suitable for the type of laying in accordance with the IEC standards in force
 -
 - the power supply is adequately protected against overloads and/or short circuits
 - the disconnection device is positioned in an easily accessible place to be able to intervene in the event of an emergency
- ⚠ Use a dedicated power supply circuit. Never use a power supply to which another appliance is also connected due to risk of overheating, electric shock or fire.
- ⚠ For the electrical connection, use a cable of sufficient length to cover the entire distance without any connection. Do not use extension cables. Do not apply other loads on the power supply.
- ⚠ After connecting the interconnection and power supply cables, ensure that the cables are arranged so that they do not exert excessive forces on the covers or electrical panels. Install the covers on the cables. Incomplete connections of the covers can lead to overheating of the terminals, electric shock or fire.
- ⚠ Any replacement of the power cable must only be carried out by qualified personnel and in accordance with current national regulations.
- ⚠ The manufacturer is not liable for any damage caused by the lack of earthing or failure to comply with the specifications in the respective diagrams.
- ⚠ The appliance is equipped with a noise filter as required by current regulations. Use selective residual current circuit breakers to compensate for the micro leakage to earth of this device.

Power line dimensioning

Use the tables below for the sizing of the power supply line and its protection device.

These are not average draw or transient peaks, but values to be considered for the correct sizing of the plant and the request of the contractual power (excluding loads due to the normal operation of the building).

- ⚠ Maximum power is reached only in exceptional cases. Therefore, the indicated trip current is suggested to guarantee a balance between machine absorption and incidence in the general system.
- ⚠ The indicated minimum cable cross-section area must be verified according to the actual conditions of the installation: length of the cable, characteristics of the electrical supply, etc.

Access to the electrical panel

⚠ Access to the electrical panel is only permitted to qualified personnel.

⚠ Before carrying out any work, ensure that the power supply is switched off.

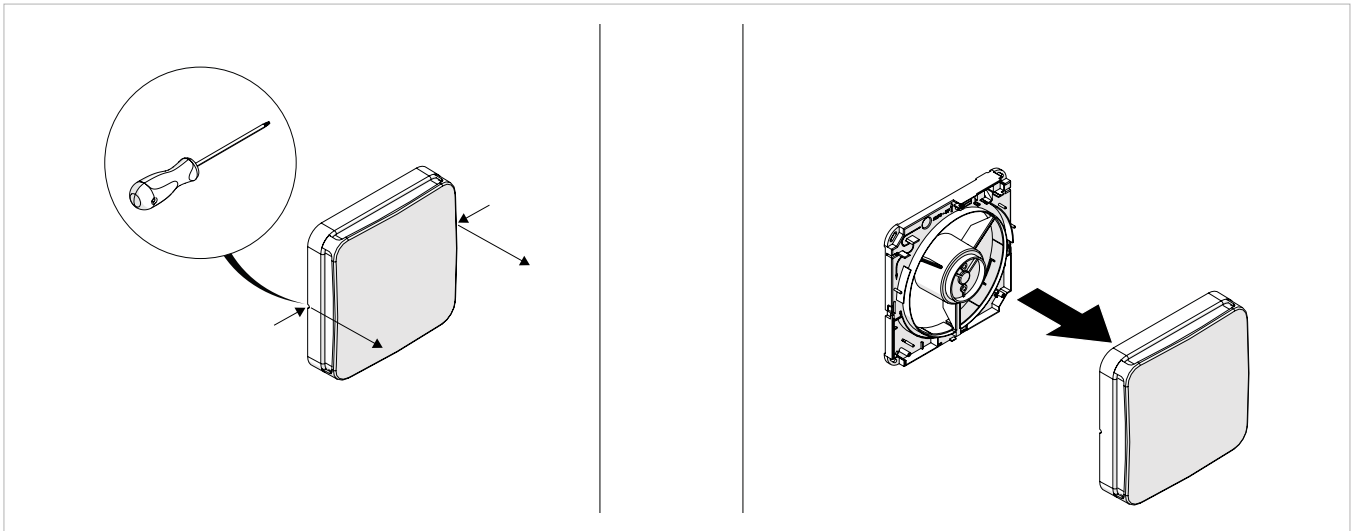

To access the connections:

► press the release points with a fine flat-head screwdriver

► pull the cover towards you

1. Flush-mounted electrical connection

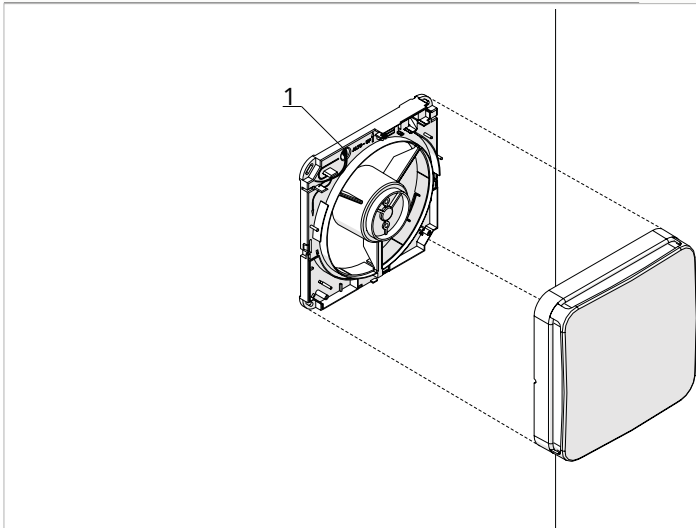

2. External electrical connection

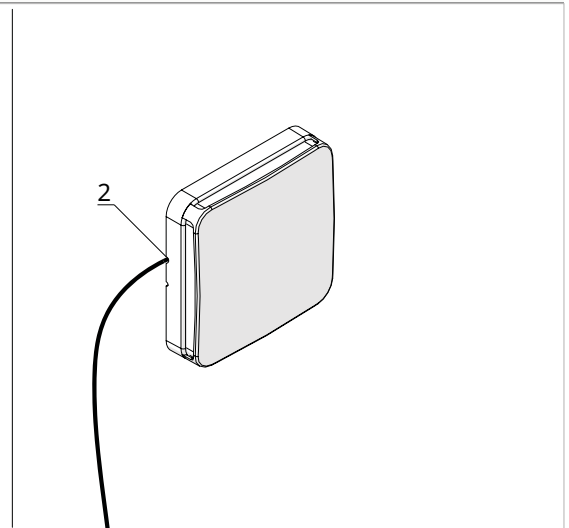

Connections

Before connecting the unit to the mains power supply, make sure that the disconnecter is open. The power supply of the single-phase unit must be connected to the appropriate terminals, subjected to the action of the isolating switch.

⚠ Use properly sized cables to avoid voltage drops or overheating.

1. Connection terminal board

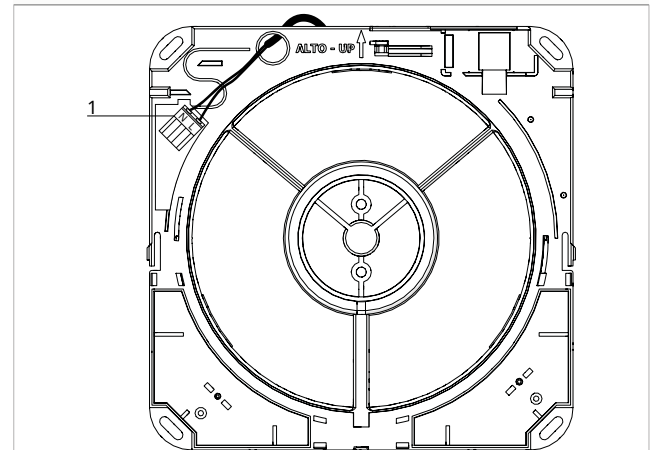

3.8 Finish

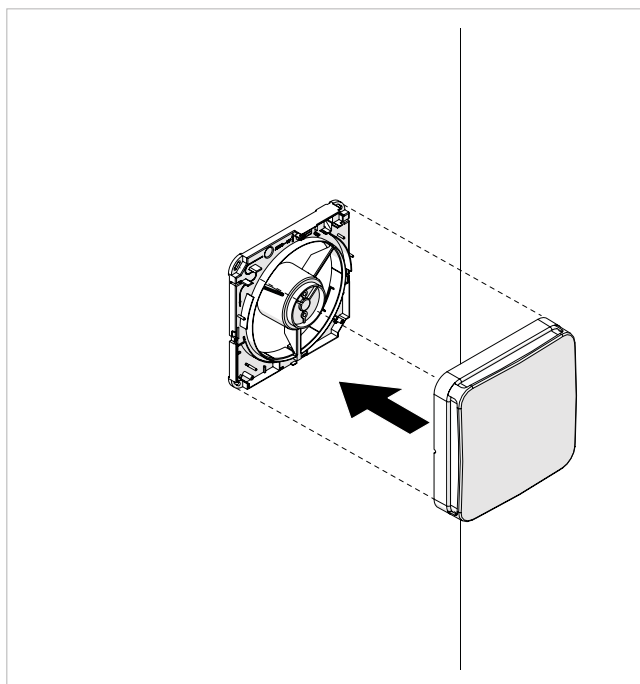

After making the electrical connections:

- ▶ attach the unit cover to the device body

4. REMOTE CONTROL

4.1 Interface

Description

The remote control has been designed to allow easy use even without particular programming. To activate it, simply insert the batteries.

Inserting the batteries

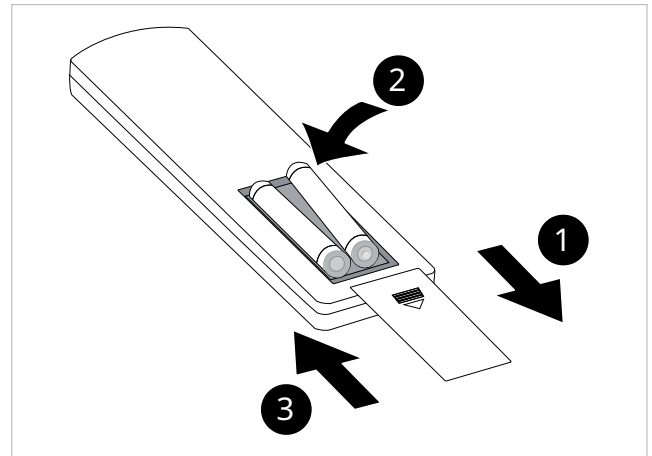

⚠ Batteries are not included. Use AAA type batteries.

Keypad key functions

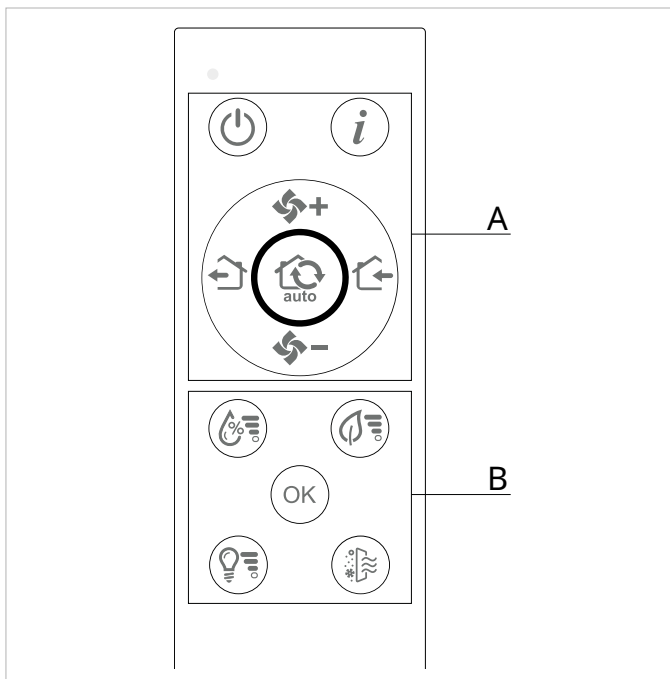

A	Basic functions
B	Advanced functions (for installer)
	On / Off button
	Info button
	Auto button (automatic timed cycle Ejection / Intake)
	Increase ventilation speed button
	Decrease ventilation speed button
	Air ejection button
	Air intake button
	Humidity sensor button
	VOC sensor button
	Confirm sensor threshold button
	Lux sensor button
	Reset filters button

General switch-on

Activation

- ▶ press the LED flashes in the color of the active mode the unit switches on

Deactivation

- ▶ press the LED flashes 4 times in red the unit switches off

5. START-UP

5.1 Preliminary Warnings

- ⚠ **This section is dedicated to the Technical Service Centre. The specifications of the Technical Service Centre are described in chapter p. 4.**
- ⚠ **Initial commissioning must be carried out by the Technical Service Centre.**
- ⚠ **For detailed information on accessories, please refer to the relevant instruction sheets.**

See chapter 2.6 p. 9

- ⚠ The customer must be present when the appliance is tested and informed of the contents of the manual and procedures. After commissioning, the manual and the warranty certificate must be handed over to the customer.
- ⚠ Before start-up, all works (electrical, hydraulic and air-flow connections) must have been completed.

5.2 First start-up

Preliminary Checks

Before commissioning, check that:

Operational checks

- all safety conditions have been met
- the unit has been properly secured to the supporting surface or wall
- the minimum technical spaces have been observed

Airflows

- the airflow connections have been made according to the instructions in the manual
- all airflow connections are correctly secured
- the ducting is correctly supported
- the ducting does not have any bottlenecks
- the ducting is thermally insulated

Electrical checks

- the cross-section of the power supply cables is adequate for the absorption of the appliance and the length of the connection made
- the electrical connections have been established correctly
- all control wires are connected and that all electrical connections are secure

Start-up

After all checks have been carried out, the unit can be put into operation.

To activate the appliance:

- ▶ please refer to the user manual

Settings

Humidity sensor

The humidity sensor allows you to assess the relative humidity. If the relative humidity value is above the set threshold, the ventilation unit switches to exhaust mode for 200 seconds at boost speed, then to the timed cycle for 180 seconds at the set speed.

If the value is again above the set threshold, the same mechanism is repeated up to 3 times in an hour.

The threshold can be varied between:

- **No threshold set:** Indicated by a slow flash of the blue LED
- **Low threshold setting 55%:** Indicated by a fast flash of the blue LED
- **Medium threshold setting 60%:** Indicated by two fast flashes of the blue LED
- **High threshold setting 65%:** Indicated by three fast flashes of the blue LED

To set the relative humidity threshold

- ▶ press and hold the button  the LED indicates the set threshold

VOC sensor

The VOC sensor allows you to assess the VOCs. If the VOC value is above the set threshold, the ventilation unit switches to exhaust mode for 200 seconds at boost speed, then to the timed cycle for 180 seconds at the set speed.

If the value is again above the set threshold, the same mechanism is repeated up to 3 times in an hour.

The threshold can be varied between:

- **No threshold set:** Indicated by a slow flash of the green LED
- **Low threshold setting 150 Index:** Indicated by a fast flash of the green LED
- **Medium threshold setting 200 Index:** Indicated by two fast flashes of the green LED

- **High threshold setting 250 Index:** Indicated by three fast flashes of the green LED

To set the relative humidity threshold

- ▶ press and hold the button 
the LED indicates the set threshold

Light sensor

The light sensor allows you to assess the brightness. If the brightness value is below the set threshold, the ventilation unit switches to night mode.

The light sensor takes precedence over the humidity and VOC sensors.

The threshold can be varied between:

- **No threshold set:** Indicated by a slow flash of the yellow LED
- **Low threshold setting 5 lux:** Indicated by a fast flash of the yellow LED
- **Medium threshold setting 10 lux:** Indicated by two fast flashes of the yellow LED
- **High threshold setting 15 lux:** Indicated by three fast flashes of the yellow LED

To set the relative humidity threshold

- ▶ press and hold the button 
the LED indicates the set threshold

Filter indication

The filter cleaning indicator is shown every 1000 hours of use, weighted based on the speeds used, by the orange LED flashing once every hour.

To reset

- press and hold the button 
the LED flashes blue

Checks with the machine switched on

After starting up, check that

Operational checks:

- verify the different modes of operation
- verify that the appliance stops and then restarts
- switch the appliance off and on again and check that it restarts correctly
- The device operates within the recommended operating conditions (see technical data table).

Electrical Checks

- the current absorbed is less than the maximum indicated in the technical data table
- the supply voltage value is within the set limits and does not fall below the nominal value -10 % during operation

5.3 Plant delivery

Once all the checks and controls on the correct operation of the plant have been completed, the installer must explain the following to the user:

- the basic functional characteristics of the appliance
- the instructions for use
- the routine maintenance

5.4 Switching off for extended periods

If the appliance is not used for a long period of time, the following steps must be taken:

- ▶ deactivating the device
- ▶ disconnect the power supply

6. MAINTENANCE

6.1 Routine maintenance

Annual operations

The once-a-year maintenance plan includes the following operations and checks and must be carried out by the Technical Service Centre or by qualified personnel.

Electrical circuit

Check:

- electrical supply voltage
- the electrical absorption
- connections tightening
- that there is no damage or excessive wear to electrical cables
- that the gaskets and sealing materials have not deteriorated to such an extent that they are no longer suitable for the purpose of preventing the development of flammable atmospheres inside
- the correct fixing of cable glands
- safety devices

Mechanical checks

Check:

- tightening of the screws, fans and electrical box, of the unit's external panelling
- the state of the structure
- ⚠ Bad fixings result in abnormal noise and vibration.

Airflow controls

Check:

- the regular flow of air
- cleaning of any intake grids
- cleaning the ducting

Cleaning

- cleaning of aesthetic cover
- cleaning or filter replacement
- cleaning the heat exchanger
- cleaning the external grid

Cleaning or filter replacement

1. Aesthetic cover
2. Filter

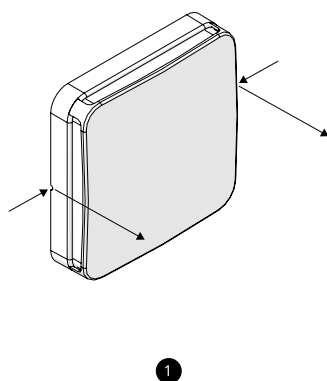

3. Cover

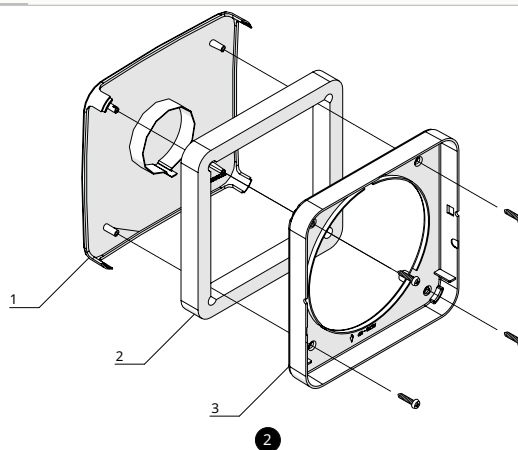

To remove:

- ▶ disconnect the power supply to the unit
- ▶ press the release points and pull the unit cover towards you
- ▶ remove the screws from the unit cover
- ▶ take out the filter
- ⚠ Pay attention to sharp surfaces

- ⓘ If the condition of the filters is acceptable, they can be cleaned using a vacuum cleaner or a low-pressure compressor.
- ⓘ If it is impossible to clean them, the filters must be replaced.

To reposition:

- ▶ proceed in reverse order

Cleaning the heat exchanger

1. Unit cover
2. Device body

3. Heat exchanger

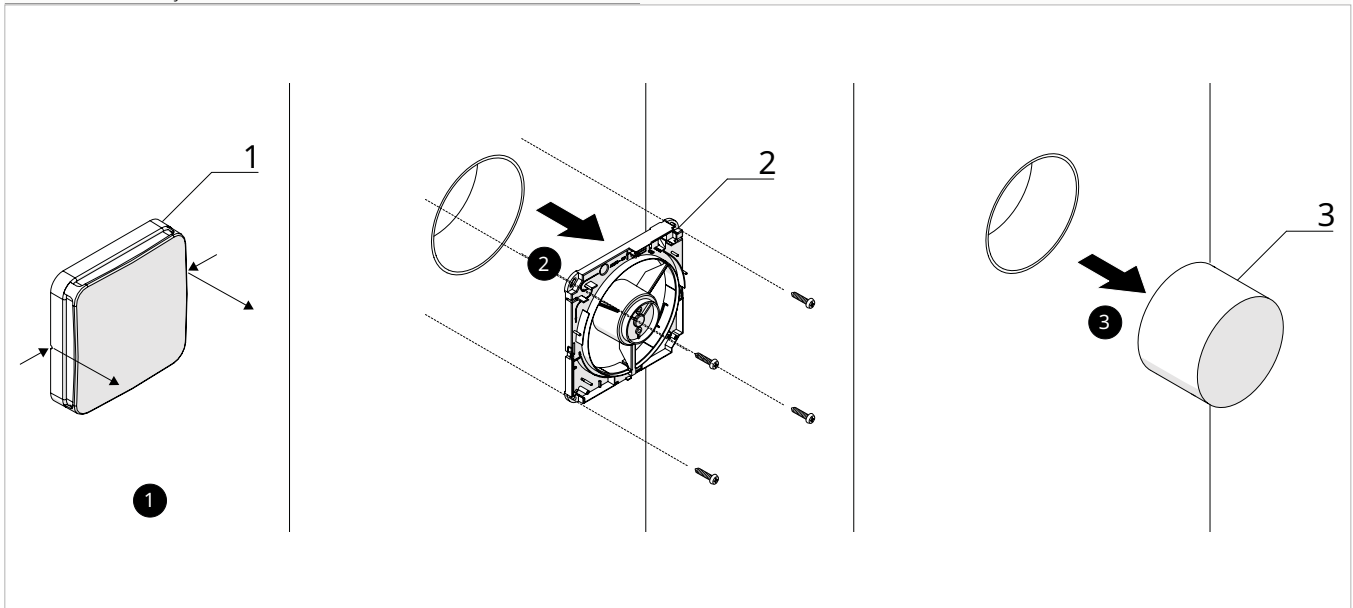

To remove:

- ▶ disconnect the power supply to the unit
 - ▶ press the release points and pull the unit cover towards you
 - ▶ remove the screws from the device body
 - ▶ extract the device body
 - ▶ use the handle provided on the heat exchanger
 - ▶ take out the heat exchanger
- ⓘ **If the condition of the heat exchanger is acceptable, it can be cleaned using a vacuum cleaner or a low-pressure compressor.**
- ⓘ **If it is impossible to clean, the heat exchanger must be replaced.**

To reposition:

- ▶ proceed in reverse order

7. FAULTS AND REMEDIES

7.1 Preliminary Warnings

If one of the following faults is found:

- ventilation does not activate
- the appliance makes excessive noise

Follow the instructions below:

- ▶ immediately disconnect the power supply
- ▶ contact an authorised Technical Assistance Centre or professionally qualified personnel
- ⚠ Work must be carried out by a qualified installer or a specialised service centre.
- ⊘ Personal intervention is prohibited.

7.2 Troubleshooting Table

Problems related to the operation of the unit

PROBLEM	CAUSE	REMEDY
The fan does not activate	The power supply is not switched on	Check the power supply on the fan
	The control unit of the unit does not work	Check the control unit and its power supply
	Incorrect electrical connections	Check the operation of the power supply
	Fan in thermal protection	Check that the fan impellers are not obstructed
The fan stops unexpectedly	Fan blades obstructed	Check the power supply on the fan
	Incorrect voltage to the motor from the control unit	Check the control unit and its power supply
	Incorrect electrical connections	Check the operation of the power supply
	Fan in thermal protection	Check that the fan impellers are not obstructed
Insufficient air flow	Clogged filter, heat exchanger, or grilles	Clean filters
	Foreign object inside the duct	Increase rotation speed
		Clean ducts, heat exchanger
Problems with the fan blades	Check the fan impellers	
Insufficient heat exchanger efficiency	Clogged heat exchanger	Clean exchanger surfaces
	Incorrectly set cycle time	Set the cycle time according to the previous instructions
Excessive vibration and noise	Incorrect installation of the unit	Check unit brackets and fastenings
	Incorrect piping installation	Check brackets and pipe fixings
	Fan impeller imbalance	Check fan impeller condition
Water leakage from the unit	Unit installation with incorrect inclination	Check the correct installation of the ventilation unit

Problems related to the operation of the control unit or power supply

PROBLEM	CAUSE	REMEDIES
The fan does not activate	Control unit malfunction	Check or replace the control unit
	Power supply malfunction	
The fan does not change speed	Control unit malfunction	Check or replace the control unit
The fan does not change operating mode	Control unit malfunction	Check or replace the control unit
The fan operates at unexpected times	Control unit malfunction	Check or replace the control unit
The remote control does not work	Dead batteries or faulty remote control	Check or replace the batteries

8. TECHNICAL INFORMATION

8.1 Technical data

Models	u.m.	02	05
Fan (UNI EN 13141-8) (1)			
Type		Axial DC Brushless	
Speeds number		3	3
Nominal air flow rate	m ³ /h	24	50
Air flow in the cycle	m ³ /h	18	38
Maximum speed air flow	m ³ /h	24	50
Average speed air flow	m ³ /h	12	25
Minimum speed air flow	m ³ /h	8	15
Maximum cycle speed air flow	m ³ /h	18	38
Average cycle speed air flow	m ³ /h	9	20
Minimum cycle speed air flow	m ³ /h	6	12
Night air flow	m ³ /h	5	10
Heat exchanger (A 7; A 20) (2)			
Type		Regenerative	
Recovery efficiency	%	79,0	77,0
Filter			
Type		Flat filter	
Efficiency		Coarse	
Sound levels (UNI EN 3741; 3744)			
Sound power transmitted to the maximum Lw structure	dB (A)	32	44
Sound power transmitted to the average Lw structure	dB (A)	26	38
Sound power transmitted to the minimum Lw structure	dB (A)	18	29
Maximum sound pressure at 1 m Lp	dB (A)	28	39
Average sound pressure at 1 m Lp	dB(A)	26,0	37,0
Minimum sound pressure at 1 m Lp	dB (A)	23	34
Electrical characteristics			
Power supply	V / ph / Hz	230 / 1 / 50	
Absorbed power	W	6,6	6,6
Protection rating	IP	X4	
Product dimensions			
Cover dimensions	mm	180 x 180	180 x 180
Diameter	mm	107	160
1. Data referring to the UNI EN 13141-8 standard			
2. External air temperature 7 °C / 72 % RH; Internal air temperature 20 °C / 28 % RH			

Models	u.m.	02	05
Duct depth	mm	Min 240 / Max 540	Min 240 / Max 540

1. Data referring to the UNI EN 13141-8 standard
2. External air temperature 7 °C / 72 % RH; Internal air temperature 20 °C / 28 % RH

8.2 Dimensions

Size 02

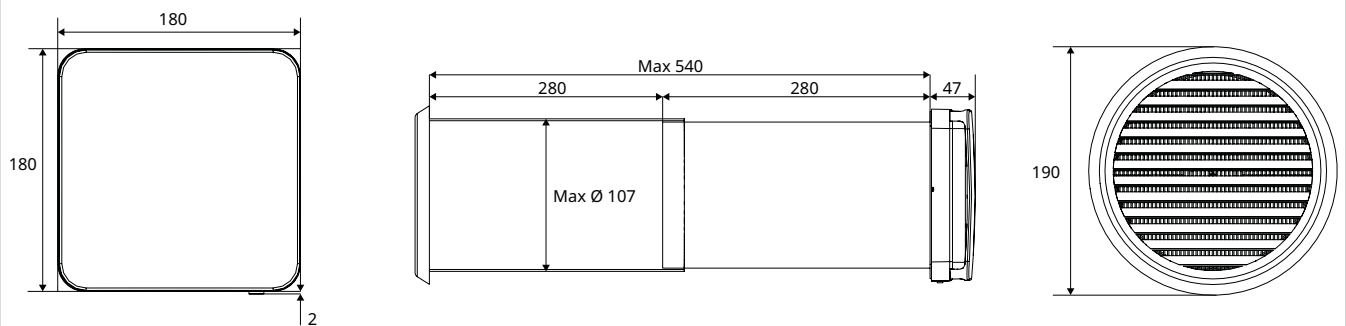

Size 05

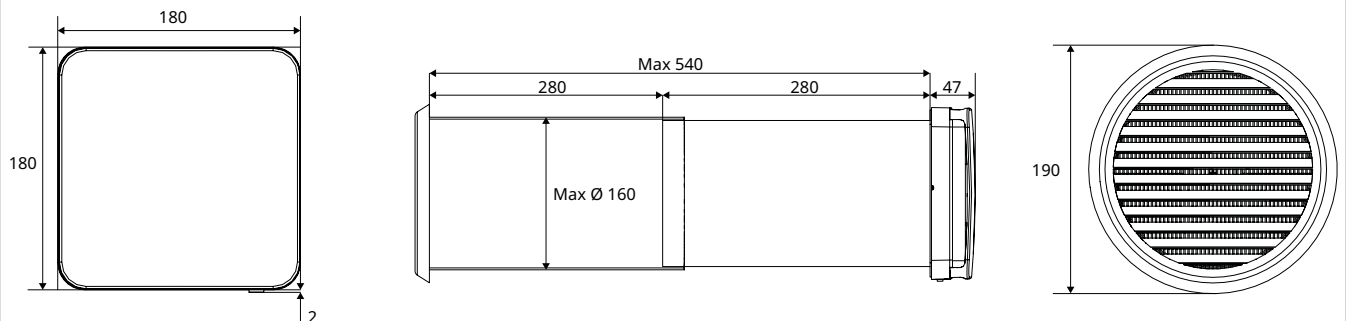



innova

INNOVA S.r.l.
Via I Maggio 8 - 38089 (TN) - ITALY
tel. +39.0465.670104 - fax +39.0465.674965
info@innovaenergie.com